

# CAST STEEL VALVE

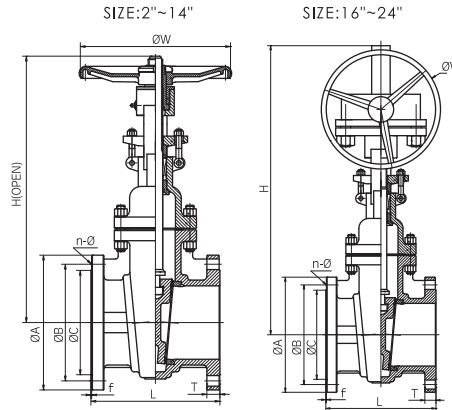

2" - 24"



G3FM411CTS-17-R0

## TYPE FM 411 CTS

- ANSI 150LBS
- BODY ASTM-A216-WCB
- FACE TO FACE ANSI B16.10, END FLANGE ANSI B16.5
- BASIC DESIGN API 600, TEST API 598
- OPTION: ANSI 300LBS, 600LBS

### Dimensions

Unit :mm

SIZE	ØA	ØB	ØC	T	f	L	H	ØW	n-Ø
2"	152	120.5	92	16	1.6	178	386	200	4-Ø19
2-1/2"	178	139.5	105	17.5	1.6	190	435	200	4-Ø19
3"	190	152.5	127	19	1.6	203	483	250	4-Ø19
4"	229	190.5	157	24	1.6	229	587	250	8-Ø19
5"	254	216	157	25	1.6	254	673	300	8-Ø22
6"	279	241.5	216	26	1.6	267	767	300	8-Ø22
8"	343	298.5	270	29	1.6	292	955	350	8-Ø22
10"	406	362	324	31	1.6	330	1146	450	12-Ø25
12"	483	432	381	32	1.6	356	1328	500	12-Ø25
14"	533	476	413	35	1.6	381	1450	550	12-Ø29
16"	597	540	470	37	1.6	406	1721	460	16-Ø29
18"	635	578	533	40	1.6	432	1900	460	16-Ø32
20"	699	635	584	43	1.6	457	2116	610	20-Ø32
24"	813	749.5	692	48	1.6	508	2480	610	20-Ø35



2" - 18"

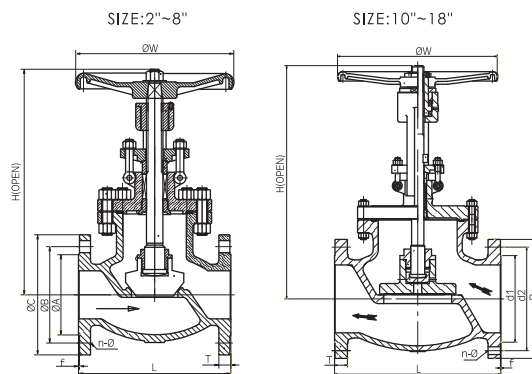

G3FM412CTS-17-R0

## TYPE FM 412 CTS

- ANSI 150LBS
- BODY ASTM-A216-WCB
- FACE TO FACE ANSI B16.10, END FLANGE ANSI B16.5
- BASIC DESIGN BS1873 & ANSI B16.34, TEST API 598
- OPTION: ANSI 300LBS, 600LBS

### Dimensions

Unit :mm

SIZE	ØA	ØB	ØC	T	f	L	H	ØW	n-Ø
2"	92	120.5	152	16	1.6	203	341	200	4-Ø19
2-1/2"	105	139.5	178	17.5	1.6	216	367	250	4-Ø19
3"	127	152.5	190	19	1.6	241	375	250	4-Ø19
4"	157	190.5	229	24	1.6	292	483	300	8-Ø19
5"	186	216	254	25	1.6	356	517	300	8-Ø22
6"	216	241.5	279	26	1.6	406	537	350	8-Ø22
8"	270	298.5	343	29	1.6	495	590	400	8-Ø22
10"	324	362	406	31	1.6	622	890	630	12-Ø25
12"	381	432	483	32	1.6	698	1045	710	12-Ø25
14"	413	476	533	35	1.6	787	1250	710	12-Ø29
16"	470	540	597	37	1.6	914	1580	750	16-Ø29
18"	533	578	635	40	1.6	978	1800	800	16-Ø32