

GLOBE VALVE

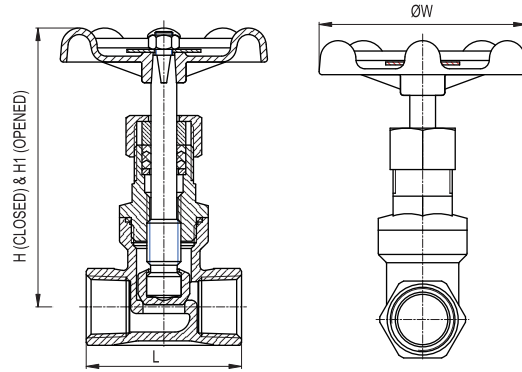

THREADED END, 1/4" - 2"

G1FM402-17-R0

TYPE FM 402

- GLOBE VALVE, 200 PSI
- BODY ASTM-A351-CF8M
- RATING 200PSI/ WOG 350°F S.P.
- FULL PORT, NON-RISING STEM, HANDWHEEL OPERATION
- SCREWED BONNET, SWIVAL DISC INTEGRAL SEAT

Dimensions

Unit :mm

SIZE	L	H	H1	ØW	WEIGHT KGS
1/4"	52	95	106	70	0.34
3/8"	52	95	106	70	0.32
1/2"	52	95	106	70	0.34
3/4"	66	100	114	80	0.45
1"	76	110	127	80	0.66
1-1/4"	86	130	150	90	0.98
1-1/2"	94	130	154	100	1.27
2"	118	139	170	100	2.03

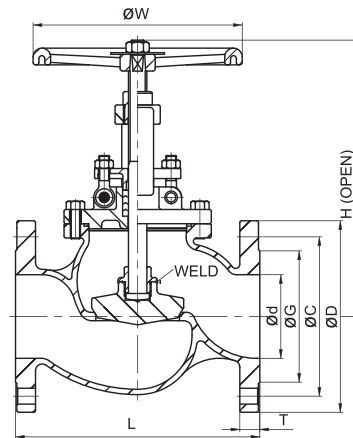

FLANGED END, 1/2" - 12"

G1FM412-17-R0

TYPE FM 412

- GLOBE VALVE, ANSI 150LBS
- BODY ASTM-A351-CF8M/ CF8
- FACE TO FACE ANSI B16.10/ JIS B2002, END FLANGE ANSI B16.5/ JIS B2239
- DESIGN ANSI B16.34, TEST API 598
- OPTION: JIS 10K/ 20K/ ANSI 300LBS/ DIN PN16

Dimensions

Unit :mm

SIZE	Ød	L	H	ØW	ØD	ØC	ØG	T
1/2"	15	108	168	140	89	60.5	35	11.1
3/4"	20	117	168	140	98	70	43	11.1
1"	25	127	173	140	108	79.5	51	11.1
1-1/4"	32	140	190	160	117	89	64	12.7
1-1/2"	40	165	200	160	127	98.5	73	14.3
2"	50	203	230	200	152	120.5	92	15.9
2-1/2"	65	216	243	200	178	139.5	105	17.5
3"	80	241	286	250	190	152.5	127	19.1
4"	100	292	325	250	229	190.5	157	23.9
5"	125	356	380	300	254	216	186	23.9
6"	150	406	445	350	279	241.5	216	25.4
8"	200	495	545	350	343	298.5	270	28.6
10"	250	622	650	400	406	362	324	30.2
12"	300	698	736	400	483	432	381	31.8