

## PULSATION DAMPENER

MODEL: FH608N-CV

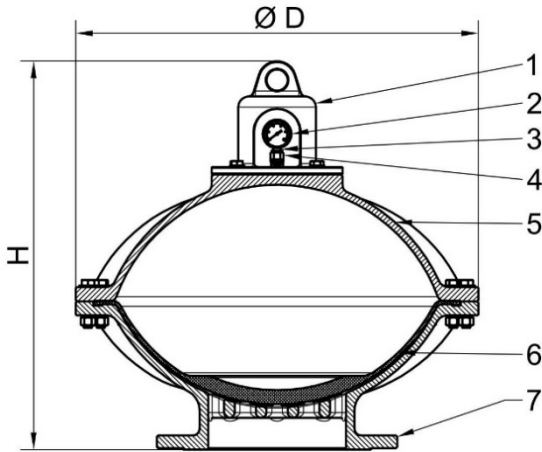

### Specification

Connection : Flange

PN10 / 16、 JIS 10K / 16K / 20K

Max working pressure : 25 Bar

Max work temperature : 100°C / 220°C

### Material of Construction

No	Parts Name	Material
1	Protective Cover	Ductile Iron
2	Pressure Gauge	-
3	Charging Port	Brass
4	Ball Valve	Brass
5	Cover	Cast Steel / Stainless Steel
6	Bladder	NBR / EPDM / VITON
7	Body	Cast Steel / Stainless Steel

### Dimension

Size (DN)	H (mm)	D (mm)	Capacity (L)
50*	237	180	0.7
65	386	290	3
80	386	290	3
100	426	360	6
125	426	360	6
150	500	503	17
200	565	570	30
250	565	570	30
300	565	570	30

\* No protective cover