

CHECK VALVE

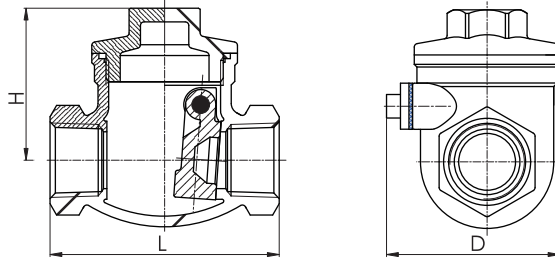

THREADED END, 1/4" - 3"

G1FM403-17-R0

TYPE FM 403

- SWING CHECK VALVE, 200 PSI
- BODY ASTM-A351-CF8M
- RATING 200PSI/ WOG 350°F S.P.
- FULL PORT, SWING TYPE DISC, INTEGRAL SEAT

Dimensions

Unit :mm

SIZE	L	H	D	WEIGHT KGS
1/4"	65	43	46.5	0.26
3/8"	65	43	46.5	0.23
1/2"	65	43	46.5	0.24
3/4"	80	53	51.5	0.36
1"	89	60	56.0	0.69
1-1/4"	105	66	64.0	0.86
1-1/2"	120	75	74.5	1.35
2"	139	80	84.0	2.37
2-1/2"	181	99	103.5	4.73
3"	200	104	152.0	7.26

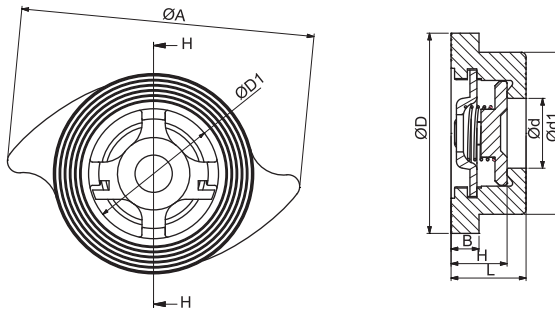

THREADED END, 1/2" - 10"

G1FM406-17-R0

TYPE FM 406

- WAFER DISC CHECK VALVE
- BODY ASTM-A351-CF8M
- RATING PN40/ PN16/ PN10/ 300LBS/ 150LBS/ JIS 10K/ 20K
- 1-PC DESIGN
- DRAWING OF 5"-10" IS OFFERED ON REQUEST (PN40)

Dimensions

Unit :mm

SIZE	Ød	Ød1	ØD	L	H	ØD1	B	A
1/2"	15	34.8	43	16	12	27.9	6	60
3/4"	20	45	53	19.5	14	35.8	7.7	69.5
1"	25	50.8	63	22	16.6	41.3	8	80.5
1-1/4"	32	60.2	72.5	28	22.3	49.2	9	90.5
1-1/2"	40	69.7	82	31.5	24.5	57	10	101
2"	50	89.8	95.2	40	33.2	76.1	8	115
2-1/2"	65	102	115.6	45	38.3	87.6	7.5	142
3"	80	121	129.4	50	42	106.2	8	153.5
4"	100	145	154.2	60	51.3	128.5	12	179.8