

# GATE VALVE

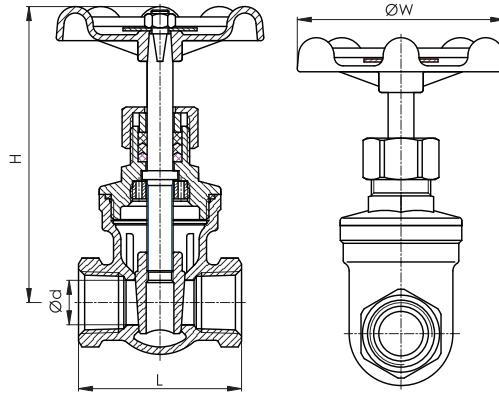

THREADED END, 1/2" - 3"

G1FM401-17-R0

## TYPE FM 401

- GATE VALVE, 200 PSI
- BODY ASTM-A351-CF8M
- RATING 200PSI/ WOG 350°F S.P.
- FULL PORT, NON-RISING STEM, HANDWHEEL OPERATION
- SCREWED BONNET, WEDGE DISC INTEGRAL SEAT

### Dimensions

Unit :mm

SIZE	Ød	L	H	ØW	WEIGHT KGS
1/2"	15	55	100	70	0.41
3/4"	20	60	107	70	0.52
1"	25	65	110	80	0.64
1-1/4"	32	75	130	80	0.98
1-1/2"	38	85	147	90	1.42
2"	50	95	170	100	2.10
2-1/2"	65	116	213	140	5.23
3"	80	130	239	140	7.06

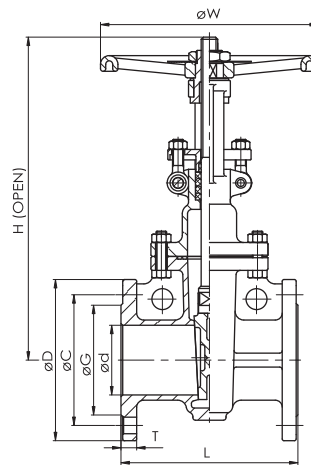

FLANGED END, 1/2" - 12"

G1FM411-17-R0

## TYPE FM 411

- GATE VALVE, ANSI 150LBS
- BODY ASTM-A351-CF8M/ CF8
- FACE TO FACE ANSI B16.10/ JIS B2002, END FLANGE ANSI B16.5/ JIS B2239
- DESIGN ANSI B16.34, TEST API 598
- OPTION: JIS 10K/ 20K/ ANSI 300LBS/ DIN PN16

### Dimensions

Unit :mm

SIZE	Ød	L	H	ØW	ØD	ØC	ØG	T
1/2"	15	108	183	120	89	60.5	35	11.1
3/4"	20	117	190	120	98	70	43	11.1
1"	25	127	210	120	108	79.5	51	11.1
1-1/4"	32	140	270	200	117	89	64	12.7
1-1/2"	40	165	270	200	127	98.5	73	14.3
2"	50	178	320	200	152	120.5	92	15.9
2-1/2"	65	190	375	200	178	139.5	105	17.5
3"	80	203	445	250	190	152.5	127	19.1
4"	100	229	523	250	229	190.5	157	23.9
5"	125	254	606	300	254	216	186	23.9
6"	150	267	710	300	279	241.5	216	25.4
8"	200	292	910	350	343	298.5	270	28.6
10"	250	330	1117	400	406	362	324	30.2
12"	300	356	1324	400	483	432	381	31.8