

# FORGED VALVE

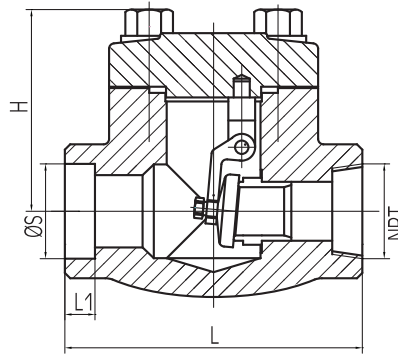

1/2" - 2"

G3FM405FDS-17-R1

## TYPE FM 403 FDS

- SWING CHECK VALVE, CLASS 800
- REDUCED PORT, DESIGN API 602, B.C (BOLT COVER)
- OPTION: MATERIAL LF2/F5/ F11/ F304/ F304L/ F316/ F316L, CLASS 150 - 800 LIFT CHECK VALVE/ CLASS 800-1500 Y TYPE LIFT CHECK VALVE

### Dimensions

Unit :mm

SIZE	L	ØS	L1	H
1/2"	79	21.8	10	62
3/4"	92	27.2	13	63
1"	111	33.9	13	78
1-1/4"	120	42.7	13	82
1-1/2"	120	48.8	13	102
2"	140	61.2	16	120

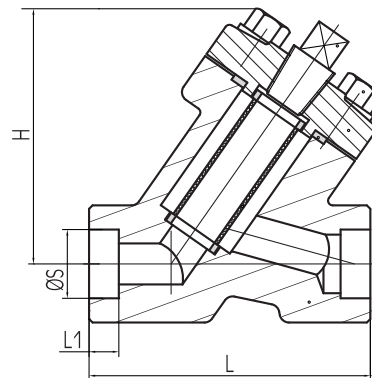

1/4" - 2"

G3FM404FDS-17-R0

## TYPE FM 404 FDS

- Y-STRAINER, CLASS 800
- DESIGN API 602, B.C (BOLTED COVER)
- OPTION: MATERIAL LF2/ F5/ F11/ F304/ F304L/ F316/ F316L

### Dimensions

Unit :mm

SIZE	L	H	ØS	L1
1/4"	98	86	21.8	10
3/4"	98	86	27.2	13
1"	120	105	33.9	13
1-1/4"	140	118	42.7	13
1-1/2"	140	120	48.8	13
2"	170	145	61.2	16