

*Go Allwhere.*

# Enhancing 5G to enable Industrial Deployment Scenarios

3GPP Rel-16 work related to private networking and IIoT requirements

Sung Hwan Won ([sung.won@nokia.com](mailto:sung.won@nokia.com))  
Industry Standards Group, Bell Labs & CTO



Private LTE

Rel-15 5G

Rel-16 5G



Private LTE

Rel-15 5G

Rel-16 5G





Transportation



Logistics & Maritime

# First verticals adopting private LTE



Manufacturing



Mining, Oil & Gas

# Private LTE – Bringing best of Wi-Fi & Ethernet’s DNA for industry verticals’ “mass adoption” business-critical wireless connectivity

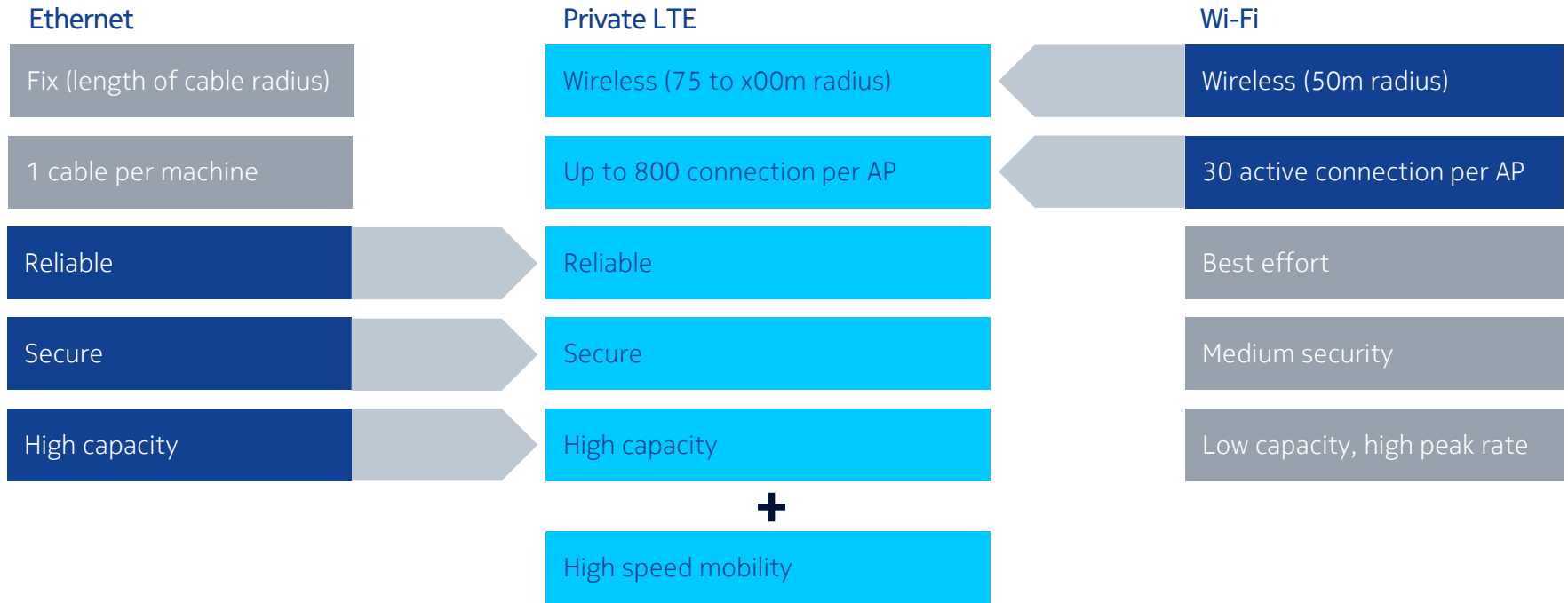







# Critical and daily communication needs of enterprises and vertical industries

## Radio access technology of choice

### Mission-critical communications

Lives at risk

Train control*	
Public safety services*	
Power plant and grid control *	

Control systems*	Mining		Mine operations*
	Airport		Airport operations*
	Oil rig		On-shore platform * Off-shore production*
	Factories		Workforce automation*

### Business-critical communications

Operational efficiency,  
security, business innovation

### Business-driven communications

Day-to-day communications

Broadband	on trains and in stations*
	in passenger terminals
	to the skies*
	in smart city hotspots*
All enterprise and verticals “normal business” communications (voice, email, etc...)*	

### LTE technologies

Technology choice (LTE, CBRS, MulteFire) depends on geographical location, environment and WAN vs LAN

Wi-Fi

\*for illustrative purposes

# Private LTE references

At least 70 enterprises deploying private LTE

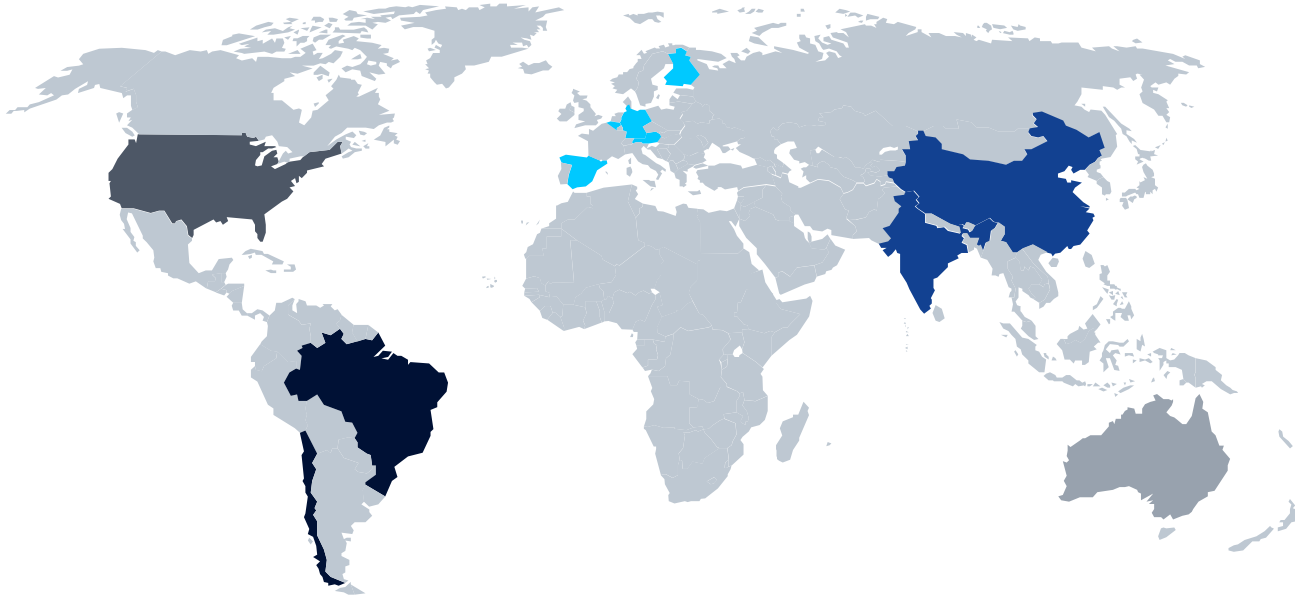

## Public references

AMEREN, USA	Nokia Chenai factory, IN
Beach Energy, AUS	Rio Tinto, AUS
BHP Bilinton Iron Ore Pty Ltd, AUS	Shanghai Pearl, CHI
BMW Brilliance Automotive Ltd, CHI	Steveko Kotka harbour, FIN
Deutsche Telekom + Inmarsat, EUR	Vienna airport, AUSTRIA
Cargotec Kalmar, SWE	
Elektro Energy, BR	
Finavia Heklsinki-Vantaa airport, FIN	
Gold Fields, AUS	
Konecranes, FIN	
Nokia Oulu factory, FIN	

Private LTE

Rel-15 5G

Rel-16 5G



# What 5G will bring compared to private LTE & vertical applicability

	LTE (4.5G Pro / 4.9G)	5G	Vertical Applications
Data rate	4.5G Pro: 1Gbps 4.9G: up to 3Gbps	>10Gbps	Venues experience (VR/AR) UL dependant apps (4K video)
Radio Latency	LTE: 10ms 4.5G Pro: 5ms 4.9G: 2ms	1ms	Car2X, Fast vehicle platooning Drone swarms Tactile/Haptic feedback robots
MU-capacity	840 active UE per sector (normal UE)	>1 million IoT devices connected per sector	Dense Smart City – people, cars, buildings, wearables, etc..
Mobility	Up to 350km/h (50ms hand-over)	Up to 500km/h (<10ms hand-over)	Car2X Fast trains
Services classes	3 services classes: LTE (hi b/w), LTE-M & NB-IoT (very low b/w)	Support more granular & flexible service classes	Improved battery life & radio efficiency with UE char. perfectly suited to use cases needs
Network slicing	Static MEC/Core/Scheduler based slicing with ltd number of slices	Dynamic AI based End2end slicing	Fully programmable network The network of network - Expand business models + Customisation of any KPI / adaptation to multiple use cases on same network

# Network slicing evolution from 4G to 5G

Network slicing will enhance CSP offering capabilities towards vertical markets

## Network slicing maximizes efficient resource and services sharing from a single physical network

Composition of adequately configured network functions, applications, and underlying cloud infrastructures to meet the requirement of a specific use case / biz model / tenant. Each slice can have a defined data rate, latency, QoS, security, availability, etc...

	4G	5G
End2End slicing	No (mostly core based)	Yes
Slicing type	Static	Dynamic
Device types	3x classes (MBB, LPWAN: NB-IoT & LTE-M)	tbd
RAN slicing	Static scheduler customisation + QoS QCI	Dynamic scheduler adaptation
Transport slicing	QCI aware	Reflective QoS support
Edge cloud application and local break out for low latency/reliability	Yes without service continuity support, Apps traffic routing is pre-defined	Yes with service continuity support, Apps can influence traffic routing
Core	<b>Ltd no. of slices.</b> Slicing by PLMN (MOCN/MORAN), APN, QCI (PCRF), DCN per UE usage type (max 1 slice/"UE usage type") and/or per virtual tenants	<b>Up to 8 slices per UE</b> (multiple slices by devices), Multiple tenant slice per UE usage types, Single enhanced policy control function (control all)
Device requirements	<b>Compatible with legacy &lt;R13 LTE UE</b>	Need post R15 devices

# Industry 4.0 use cases require a new networking approach

## 5G and next generation architecture enhancements

### 5G System

(Network of Networks, support of multiple radio technologies)

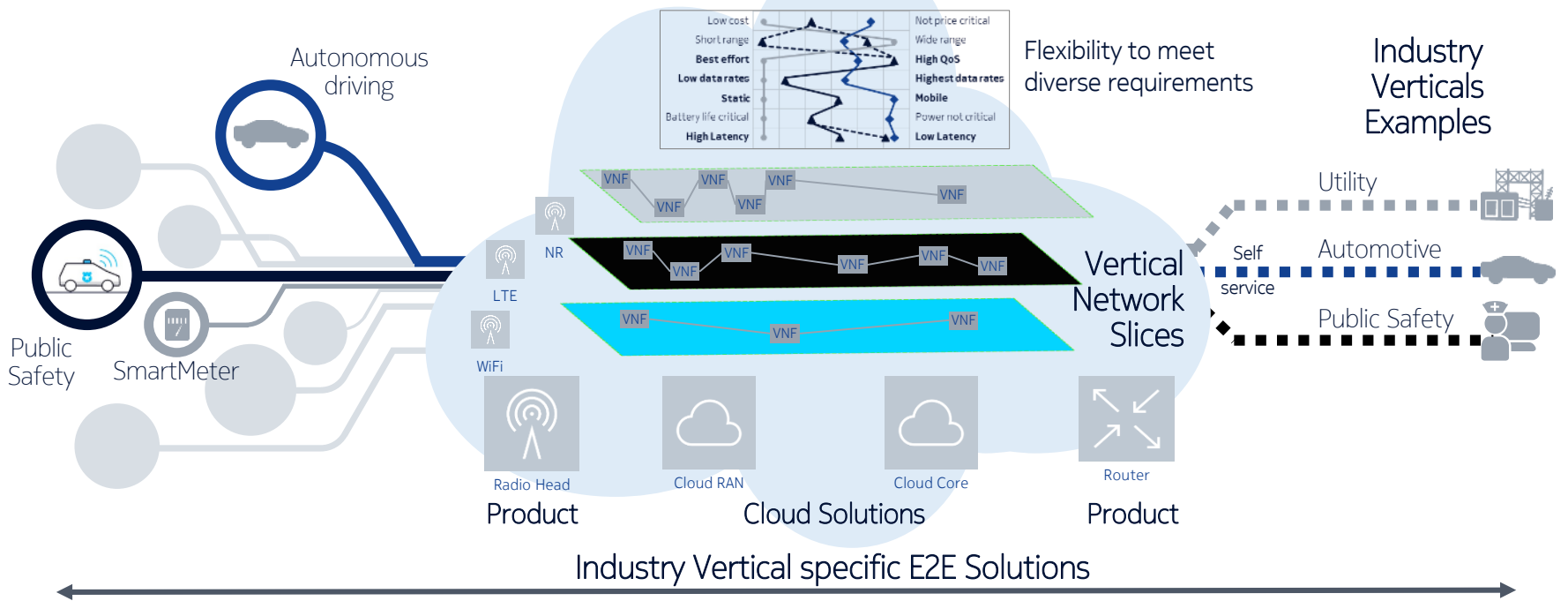

Private LTE

Rel-15 5G

Rel-16 5G



# 3GPP Work on IoT and private networks topics as part of Rel-16

## Enhancements for latency and reliability in Radio and E2E

- Rel-16: new use cases with higher requirements
- Higher reliability with multi-connectivity, 0 ms HO, L1 enhancements
- Better efficiency with enhancements to data duplication and eMBB-URLLC mux



## Industrial IoT in 5GS and NR

- Support for Wireless Industrial Ethernet and deterministic communications
- Enhancements for global time synchronization, deterministic QoS, time-sensitive flows



## 5G Private Networks in licensed and unlicensed bands

- Enable easy and cost effective deployment of industrial private networks
- Enhancements to support Non-Public and Closed Access Group (CAG) Networks



## Positioning for 5G and IoT

- Positioning enabling Lower bandwidth, lower complexity and lower cost at UE
- Positioning with scalable bandwidth and beamforming
- NR based positioning reference symbols



## Cellular IoT evolution

- Enabling connecting eMTC/NB-IoT to 5G Core
- New NR IoT UE categories for use cases beyond NB-IoT/eMTC, such as surveillance cameras

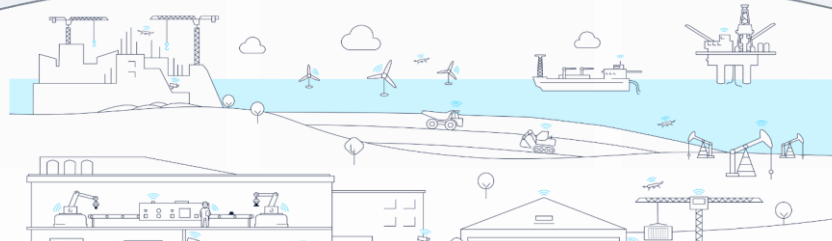

Requirements : 12/18

Architecture and concepts : 6/19

Detailed specification completed : 12/19

ASN.1 code : 3/20

3GPP Rel 16 Schedule

# Enhancements for latency and reliability in Radio and E2E

## Release 16 URLLC aims for higher reliability and better efficiency

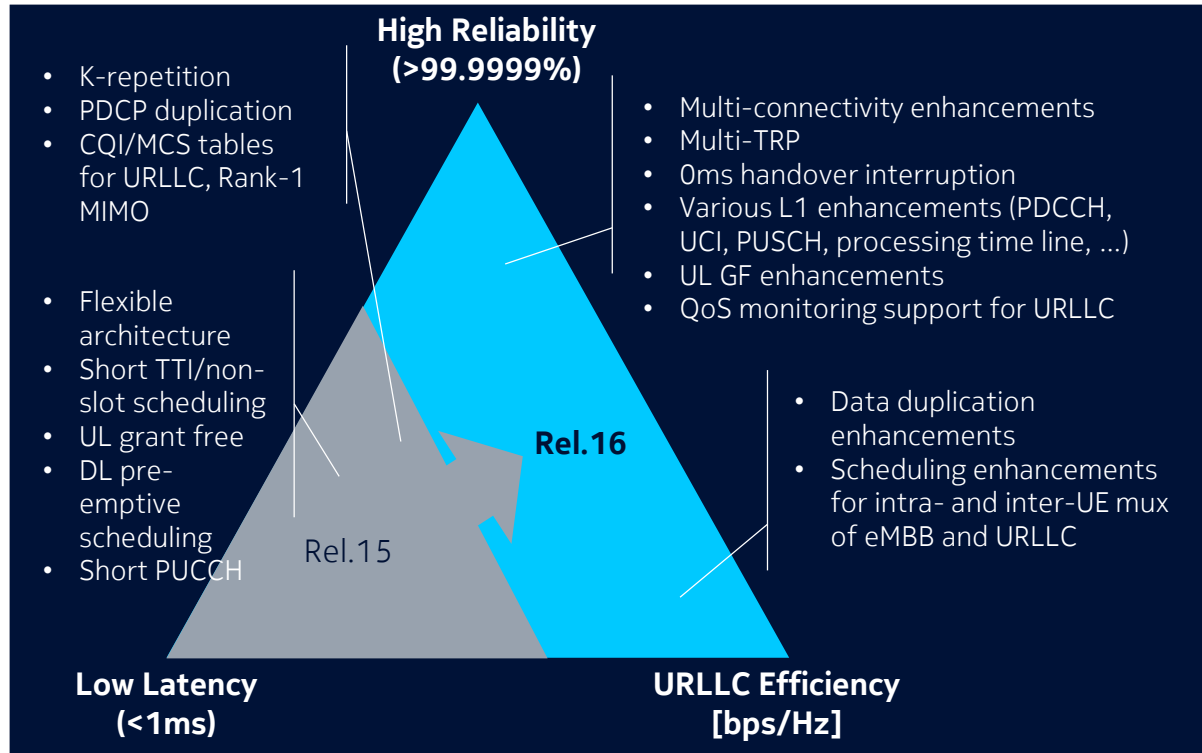

URLLC use cases considered:

- Improvements for R15 use cases (e.g. AR/VR)
- New R16 industrial IoT use cases with higher requirements



Key Rel.16 SI/WIs	Primary WG
FS_5G_URLLC ( <a href="#">SP-180118</a> )	SA2
NR_IIoT ( <a href="#">RP-181479</a> )	RAN2
NR_Mob_enh ( <a href="#">RP-181433</a> )	RAN2
NR_eURLLC_L1 ( <a href="#">RP-181477</a> )	RAN1
NR eMIMO ( <a href="#">RP-181453</a> )	RAN1

# Industrial IoT with 5GS and NR

## 5G Time Sensitive Communications (TSC)

Support for Wireless Industrial Ethernet (IEEE TSN) and multi-hop/internet deterministic communications (aka IETF DetNet)

New R16 enablers on top of enhanced URLLC:

- i. Common understanding of global time among devices and network
- ii. Network to support bounded latencies (both min and max) and error rates for packet transport
- iii. More detailed service descriptors for TSC flows (a condition for deterministic forwarding in TSN/DetNet)

Key Rel. 16 SI/WIs	Primary WG
NR_IIoT ( <a href="#">RP-181479</a> )	RAN2
FS_Vertical_LAN ( <a href="#">SP-180507</a> )	SA2
5G_LAN ( <a href="#">SP-180593</a> )	SA1
cyberCAV ( <a href="#">SP-180321</a> )	SA1

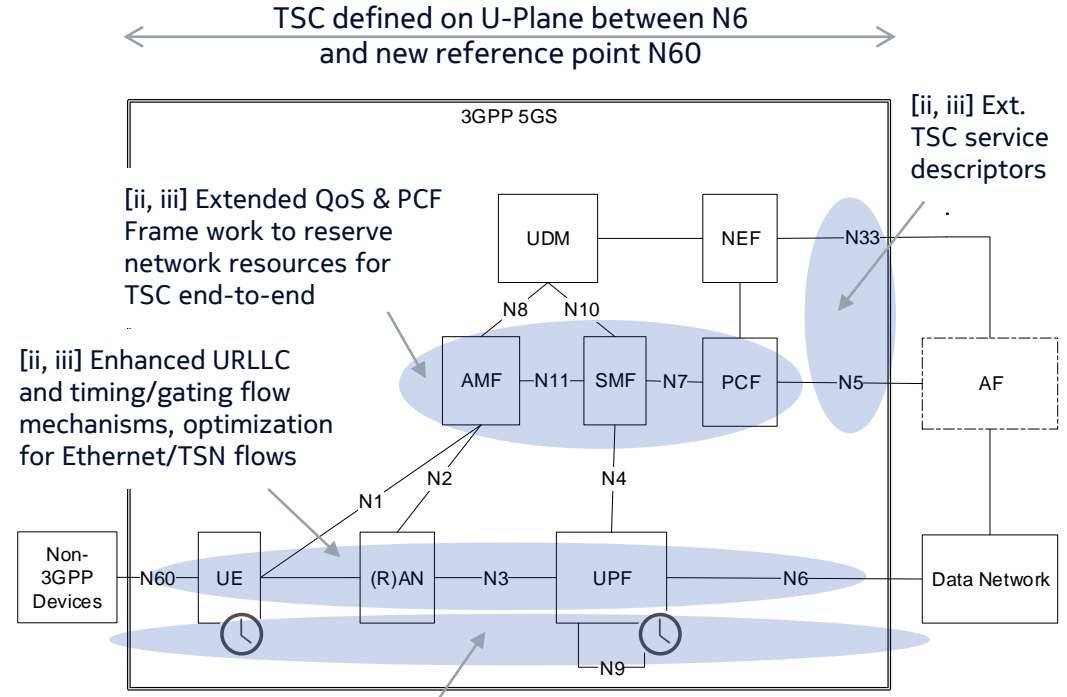

# 5G System integrated with TSN system as a TSN bridge

## Achieving transparency to the TSN network

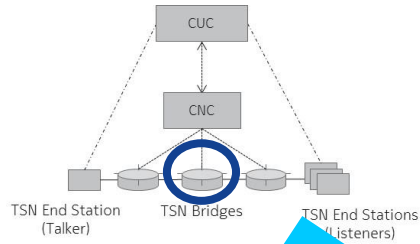

The 5GS to appear as any other TSN Bridge, the 5GS provides TSN ingress and egress ports via the **TSN Translator (Device)** functionality in the UE side and via the **TSN Translator (CP and UP)** functionality on the 5GC side towards the DN.

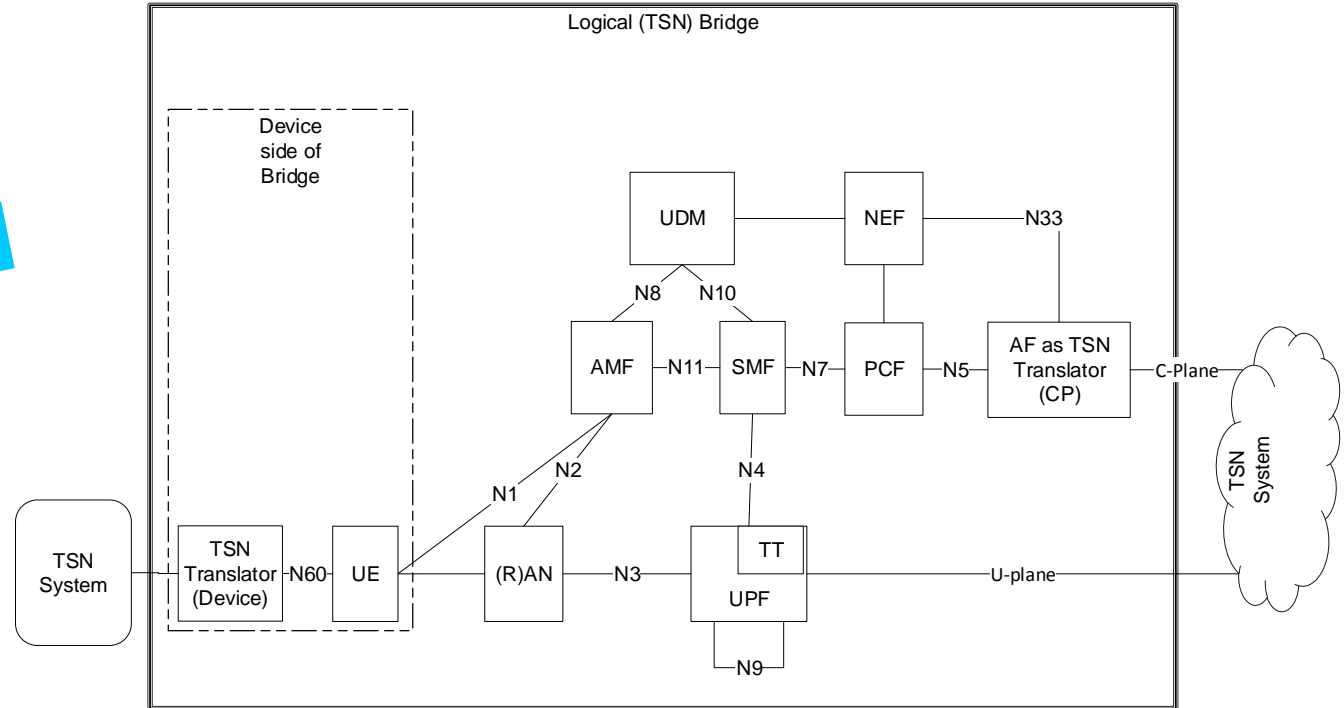

Figure 4.4.3-1: System architecture view with 5GS appearing as TSN bridge; from 3GPP TS 23.501

# 5G Private Networks in licensed and unlicensed bands

## Non-Public and Closed Access Group Networks

Enhancements to the 5G System to support non-public and MNO-hosted closed access group (CAG) networks in terms of:

- Network discovery and selection
- Roaming between CAG and public networks
- Access control and mobility
- Support of 5G LAN service

## Operation in Licensed and Unlicensed Spectrum

Introduce 5G standalone operation in unlicensed spectrum enabling easy and cost effective deployment of industrial private networks

## Two options for deploying private networks

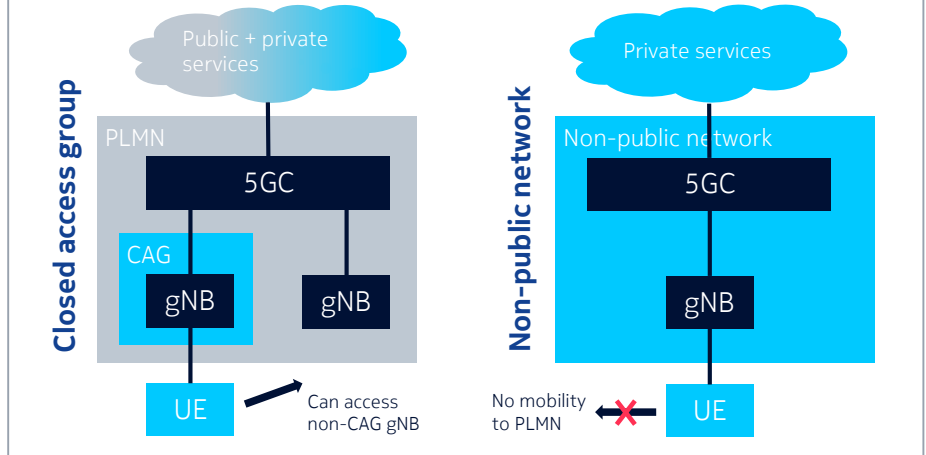

Key Rel.16 SI/WIs	Primary WG
FS_NR_unlic ( <a href="#">RP-181339</a> )	RAN1
FS_Vertical_LAN ( <a href="#">SP-180507</a> )	SA2
cyberCAV ( <a href="#">SP-180321</a> )	SA1

## Licensed and unlicensed band operation

	Unlicensed	Licensed
Importance of <b>cost &amp; ease of deployment</b>	High	Moderate
Achievable <b>reliability &amp; latency of communication</b>	Low	High

# „Non-public Network“ deployment scenarios

## Privat Networks deployed with Public Networks

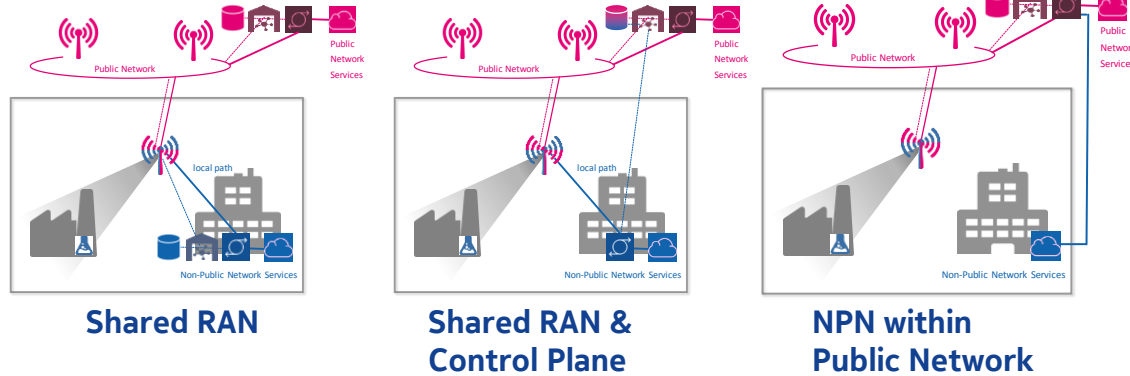

- Joint operation with Public Networks opens door for easier co-operation with them e.g. for global coverage
- Sharing resources and outsourcing allows focus to core business

## Isolated Private deployment

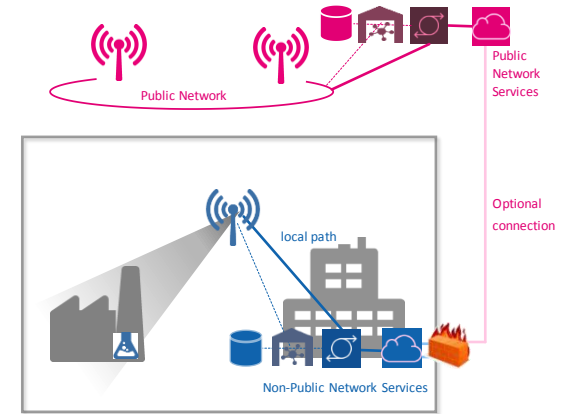

- Dedicated resources and physical separation from other networks
- Flexibility (within supported features) for customization for needs of OT specific use cases

# Positioning for 5G and IoT

## 3GPP Rel-16 introduces native-5G positioning, enabling a variety of IoT positioning methods and location services

NR-based and non-NR scalable positioning solutions, above and below 6 GHz, for E-CID and OTDOA.

### IoT:

- Lower bandwidth, lower complexity and lower UE cost
- Allow long-term & infrequent positioning measurements

### URLLC:

- High accuracy, low latency, high reliability positioning

### NR enablers:

- Spatial domain with beamforming
- Positioning with scalable bandwidth
- NR based positioning reference symbols (NR PRS)
- Hybrid positioning of OTDOA, E-CID, GNSS and sensors

### Key Rel.16 SI/WIs

### Primary WG

FS\_NR\_POS ([RP-181399](#))

RAN1

FS\_eLCS ([SP-170937](#))

SA2

5G\_HYPOS ([SP-180329](#))

SA1

- R16 positioning will support multiple use cases, including industry, logistics, eHealth and aeronautics with a common NR-based architecture.
- NR positioning exploits high bandwidth, massive antenna systems and supports massive number of devices.

5G will exploit multiple positioning technologies, including hybrid combinations

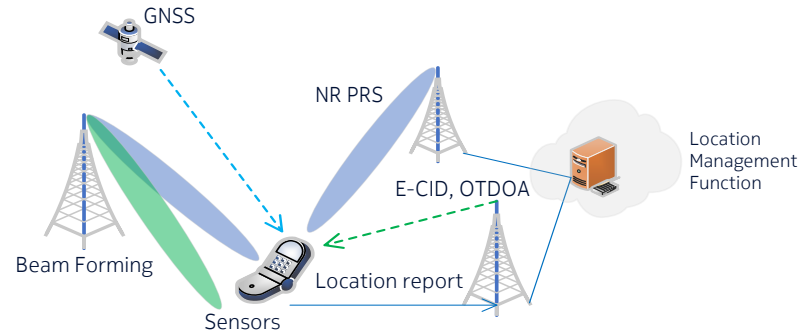



# Go Allwhere.

Networking solutions for the new age of industry.

[nokia.com/networks/go-allwhere](http://nokia.com/networks/go-allwhere)

**NOKIA**