

MAHLE

Driven by performance

Low Pressure Filter

Pi 260

Nominal pressure 25 bar (360 psi), nominal size up to 1100

1. Features

Compact, ready-to connect filter for gear boxes, lubrication and hydraulic systems

- Provided for pipe installation
- Modular system for optimal filter selection
- Low space requirements due to compact design
- Weight optimised design
- Minimal pressure drop due to the high efficiency and the volume flow optimised design of parts
- Visual/electrical maintenance indicators
- Drain outlet clean side
- Drain outlet dirt side
- Permanent venting
- Equipped with highly efficient MAHLE Premium Select filter elements
- Guaranteed retention rates according to ISO 16889 multipass test
- Defined cleanliness classes according to ISO 4406
- High dirt holding capacity
- Easy to service
- Worldwide sales and service



2. Flow rate/pressure drop curve (filter housing incl. element)

— 500 mm²/s
— 190 mm²/s
— 33 mm²/s

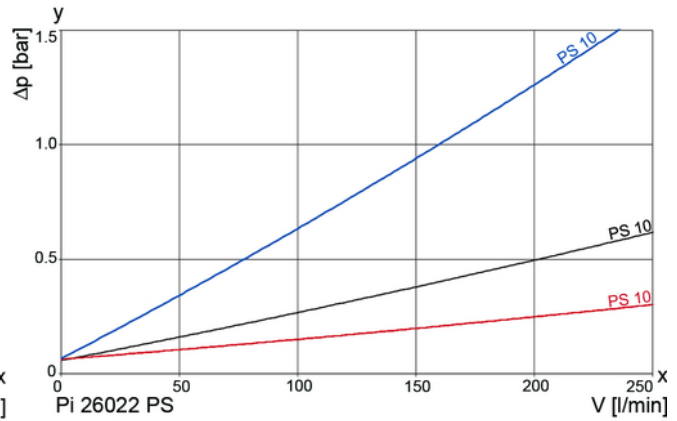
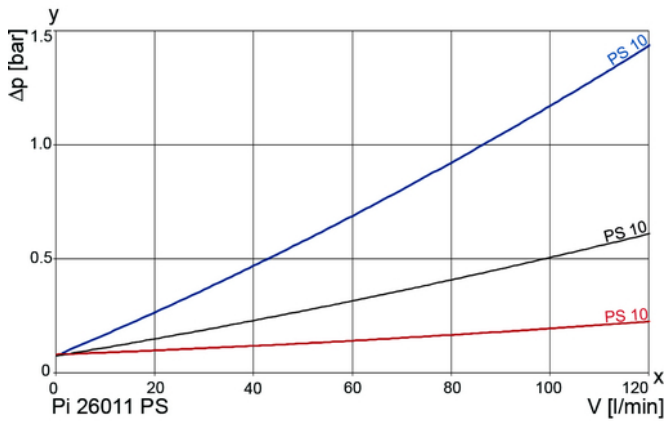

y = differential pressure Δp [bar]

x = flow rate V [l/min]

A wider range of grade of filtration on request.

3. Mode of operation

Due to the high filter surface, the filter is suitable for high viscous lubricating oils, used for example in gear boxes for wind mill generators and in paper machines. An additional feature is the individual fitting position. Connections (drain outlet dirt side, drain outlet clean side and indicator) are already provided at both sides of the filter head. Therefore the connections meet all customers requirements. The filter is fitted with a 2-step filter element with MAHLE Premium Select (PS) filter media.

The first filtration stage consists a 10 μm fine filter and the second

stage a 50 μm safety filter. Other degrees of filtration are available on request.

For monitoring the filter element, optional a differential pressure indicator is available. For customized requirements we offer a wide range of MAHLE differential pressure indicators with 1 or 2 setting-points, LED indicators, various types of contacts, analog outputs, temperature suppression and connecting plugs.

The filter series is available for all mineral-oil-based gear box and lubrication oils.

4. Separation grade characteristics

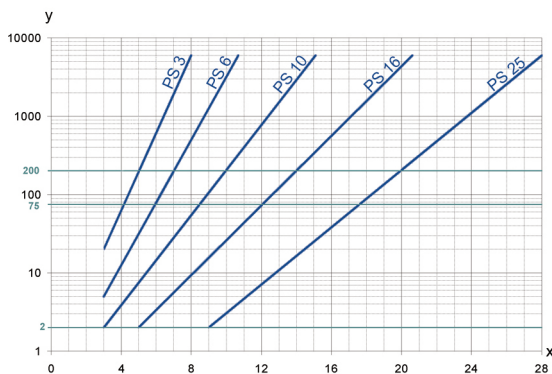

y = beta-value

x = particle size [μm]

determined by multipass tests (ISO 16889)

calibration according to ISO 11171 (NIST)

5. Filter performance data

tested according to ISO 16889 (Multipass-Test)

PS elements with max. Δp 10 bar

PS 3 $\beta_{5(C)} \geq 200$

PS 6 $\beta_{7(C)} \geq 200$

PS 10 $\beta_{10(C)} \geq 200$

6. Quality assurance

MAHLE filters and filter elements are produced according to the following international standards:

Norm	Designation
DIN ISO 2941	Hydraulic fluid power filter elements; verification of collapse/burst resistance
DIN ISO 2942	Hydraulic fluid power filter elements; verification of fabrication integrity
DIN ISO 2943	Hydraulic fluid power filter elements; verification of material compatibility with fluids
DIN ISO 3723	Hydraulic fluid power filter elements; method for end load test
DIN ISO 3724	Hydraulic fluid power filter elements; verification of flow fatigue characteristics
ISO 3968	Hydraulic fluid power-filters-evaluation of pressure drop versus flow characteristics
ISO 10771.1	Fatigue pressure testing of metal containing envelopes in hydraulic fluid applications
ISO 16889	Hydraulic fluid power filters-multipass method for evaluation filtration performance of a filter element

7. Symbols

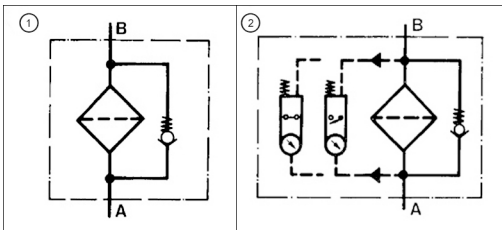

Bypass valve is integrated into the filter element.

8. Order numbers

Example for ordering filters:

1. Filter housing	2. Filter element
V = 650 l/min with visual/electrical maintenance indicator Type: Pi 260065-134 Order number: 70526941	PS 10 Type: 852 099 PS 10/Drg 50/V 5.0 Order number: 70514957

8.1 Housing design

Nominal size NG [l/min]	Order number	Type	①	②
			no options	with visual/ electrical indicator
650	70516485	Pi 260065-046		
	70526941	Pi 260065-134		
1100	70519705	Pi 260110-046		
	70526942	Pi 260110-134		

8.2 Filter elements (a wider range of element types is available on request)

Nominal size NG [l/min]	Order number	Type	Filter material	max. Δp [bar]		Filter surface [cm ²]
650	70535473	852 099 PS 3/V 5.0	PS 3	10	Fine filter	22100
	70535472	852 099 PS 6/V 5.0	PS 6	10	Fine filter	22100
	70535470	852 099 PS 10/V 5.0	PS 10	10	Fine filter	22100
	70534327	852 099 PS 6/Drg 50/V 5.0	PS 6	10	Fine filter	22100
			Drg 50		Safety filter	2525
	70514957	852 099 PS 10/Drg 50/V 5.0	PS 10	10	Fine filter	22100
Drg 50			Safety filter		2525	
1100	70535476	852 100 PS 3/V 5.0	PS 3	10	Fine filter	52000
	70535475	852 100 PS 6/V 5.0	PS 6	10	Fine filter	52000
	70535474	852 100 PS 10/V 5.0	PS 10	10	Fine filter	52000
	70535918	852 100 PS 6/Drg 50/V 5.0	PS 6	10	Fine filter	52000
			Drg 50		Safety filter	5200
	70514957	852 100 PS 10/Drg 50/V 5.0	PS 10	10	Fine filter	52000
Drg 50			Safety filter		5200	

9. Technical specifications

Type:	Pi 260065	Pi 260110
Nominal pressure:	25 bar/363 psi	25 bar/363 psi
Test pressure:	40 bar/581 psi	40 bar/581 psi
Oil temperature:	-40 to +100 °C	-40 to +100 °C
Temperature range:	+60 °C	+60 °C
Bypass setting:	5 bar/72 psi	5 bar/72 psi
Maintenance indicator setting:	3.5 bar/51 psi	3.5 bar/51 psi
Electrical data of maintenance indicator:		
Maximum voltage:	250 V AC/200 V DC	250 V AC/200 V DC
Maximum current:	1 A	1 A
Contact load:	70 W	70 W
Type of protection:	IP 65 in inserted and secured status	IP 65 in inserted and secured status
Contact:	normally open/closed	normally open/closed
Cable connection:	M20x1.5	M20x1.5
Connection suction side*:	G/SAE 2.5	G/SAE 2.5
Connection pressure side*:	G/SAE 2.5	G/SAE 2.5
Viscosity range:	10 – 10,000 mm ² /s	10 – 10,000 mm ² /s
* G/SAE 2 connections optional		

The switching function can be changed by turning the electric upper part by 180° (normally closed contact or normally open contact). The state on delivery is a normally closed contact. By inductivity in the direct current circuit the use of suitable protection circuit should be considered. Further maintenance indicator details and designs are available in the maintenance indicator data sheet.

We draw attention to the fact that all values indicated are average values and do not always occur in specific cases of application. Our products are continually being further developed. Values, dimensions and weights can change as a result of this. Our specialized department will be pleased to offer you advice.

We recommend you to contact us concerning applications of our filters in areas governed by the EU Directive 94/9 EC (ATEX 95). The standard version can be used for liquids based on mineral oil (corresponding to the fluids in Group 2 of Directive 97/23 EC Article 9). If you consider to use other fluids please contact us for additional support.

Subject to technical alteration without prior notice!

10. Dimensions

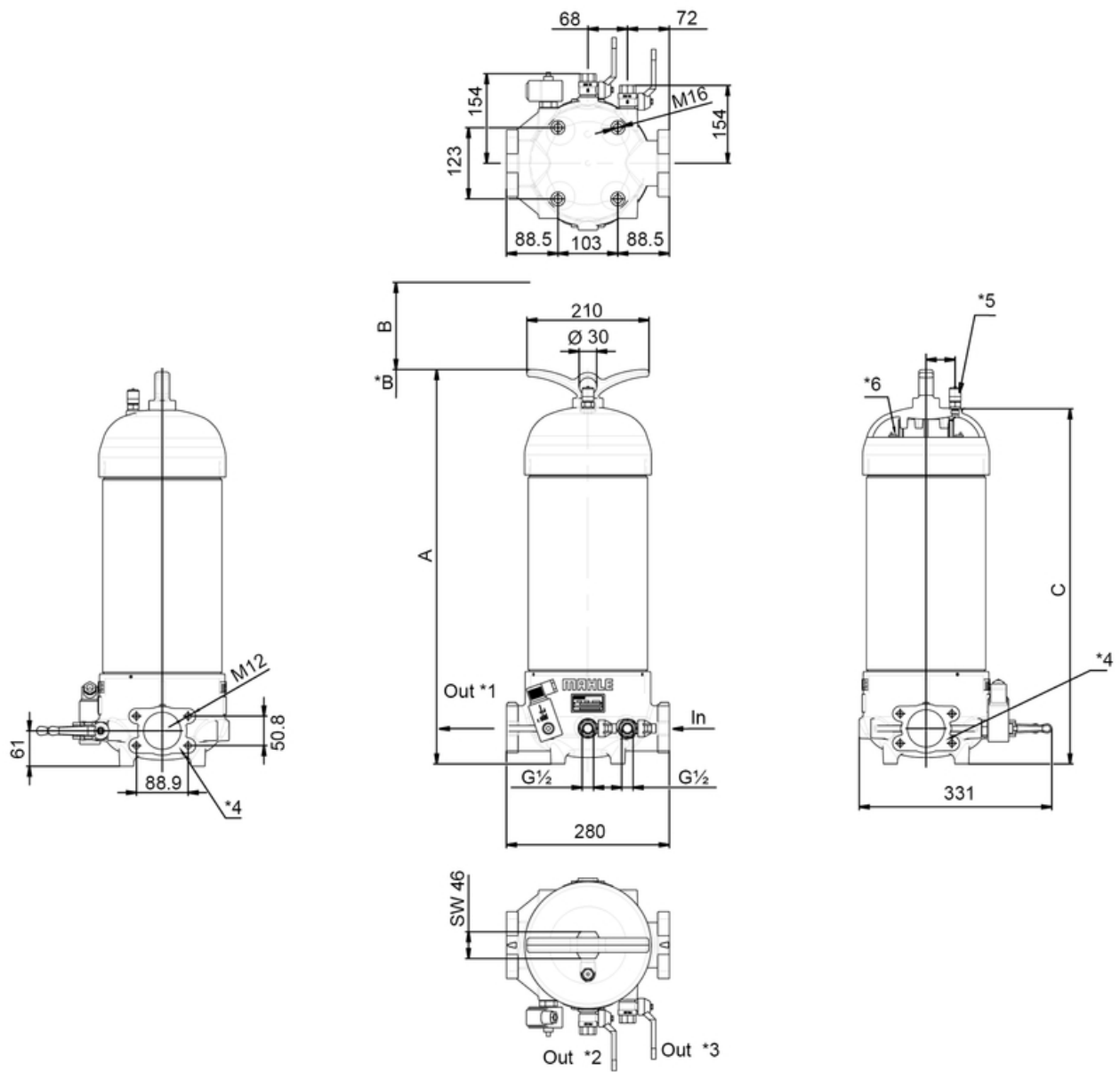

Out *1 Outlet
 Out *2 Drain outlet clean side
 Out *3 Drain outlet dirt side
 *4 SAE flange ISO 6162-1 DN64

*5 Connection permanent venting
 *6 Element removal via bow
 *B Minimum clearance for filter element
 In Inlet

All dimensions in mm.

Type	A	B	C
260065	667	440	611
260110	1197	970	1141

11. Installation, operating and maintenance instructions

11.1 Filter installation

When installing the filter make sure that sufficient space is available to remove filter element and filter housing. Preferably the filter should be installed with the filter housing pointing upwards.

Der The maintenance indicator must be visible.

11.2 Connecting the electrical maintenance indicator

The electrical indicator is connected via a 2-pole appliance plug according to DIN EN 175301-803 with poles marked 1 and 2. The electrical section can be inverted to change from normally open position to normally closed position or vice versa.

11.3 When should the filter element be replaced?

- Filters equipped with visual and electrical maintenance indicator:
During cold starts, the indicator may give a warning signal. Press the red button of the visual indicator once again only after operating temperature has been reached. If the red button immediately pops up again and/or the electrical signal has not switched off after reaching operating temperature, the filter element must be replaced after the end of the shift.
- Filters without maintenance indicator:
The filter element should be replaced after the trial run or flushing of the system. Afterwards follow instructions of the manufacturer.
- Please always ensure that you have original MAHLE spare elements in stock: Disposable elements (PS) cannot be cleaned.

11.4 Element replacement

- Stop system and relieve filter module from pressure.
- Unscrew the cover with an open-end wrench and remove it.
- Open the drain and discharge the housing completely.
- Remove element out of the housing carefully.
- Check seals on the filter housing for damage. Replace, if necessary.
- Make sure that the order number on the spare element corresponds to the order number of the filter name-plate.
To ensure no contamination occurs during the exchange of the element first open the plastic bag and push the element over the spigot in the filter head. Now remove plastic bag.
- Close the drain.
- Tighten the cover with an open-end wrench.
- Vent the filter.

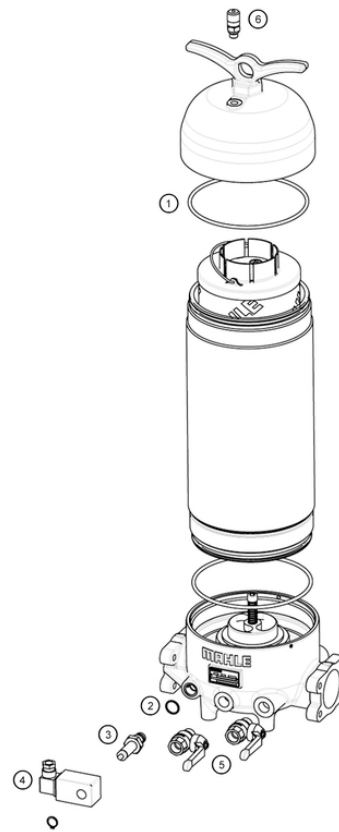

12. Spare parts list

Order numbers of spare parts and optional accessories		
Position	Type	Order number
① to ②	Seal kit complete	
	NBR	70523436
③ to ④	Maintenance indicator	
	Visual PiS 3098/3.5	77938582
	Electrical PiS 3097/3.5	78236648
	Electrical upper section only	77536550
⑤	Ball valve drain outlet dirt side/ outlet clean side	70518114
⑥	Ventilation system connection	70518145

MAHLE Industriefiltration GmbH
Schleifbachweg 45
D-74613 Öhringen
Phone +49 7941/67-0
Fax +49 7941/67-23429
industriefiltration@mahle.com
www.mahle.com
70531449.04/2015