

REVISIONS			
REV.	DESCRIPTION	DATE	APPROVED
REL-01		12/8/2006	

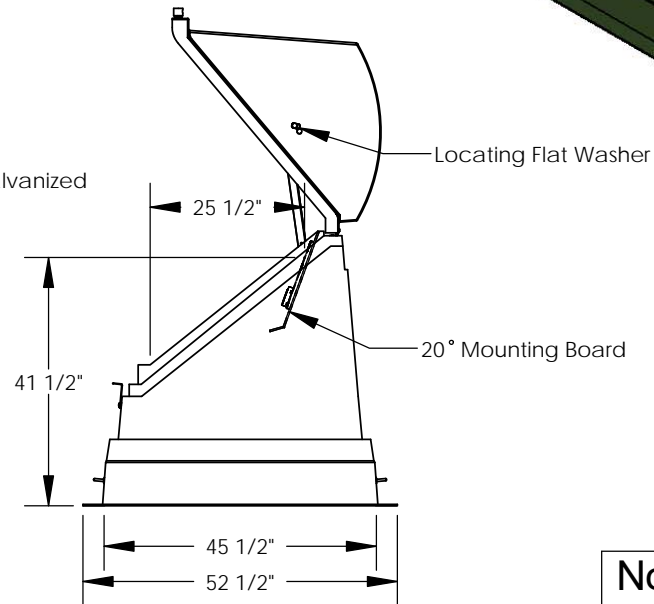
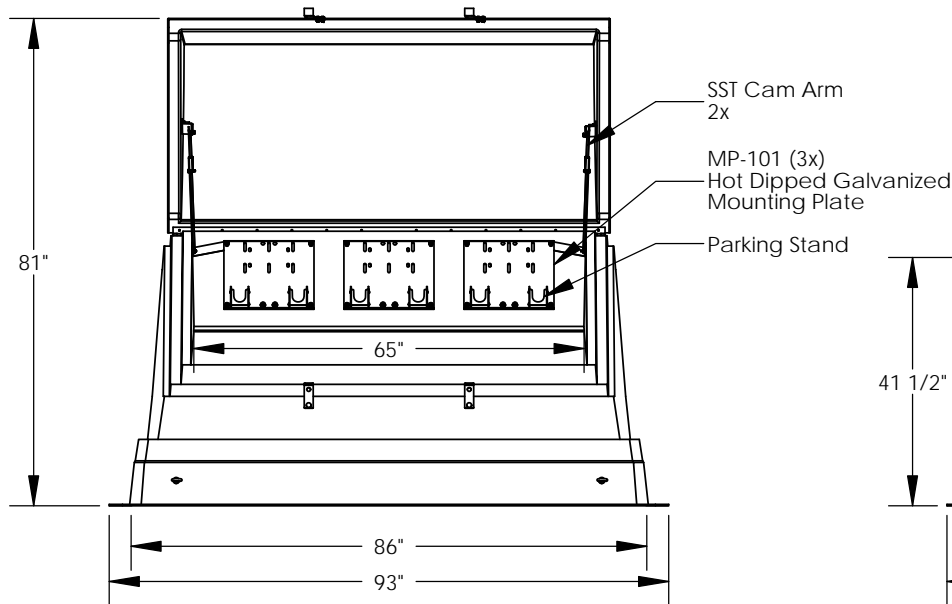
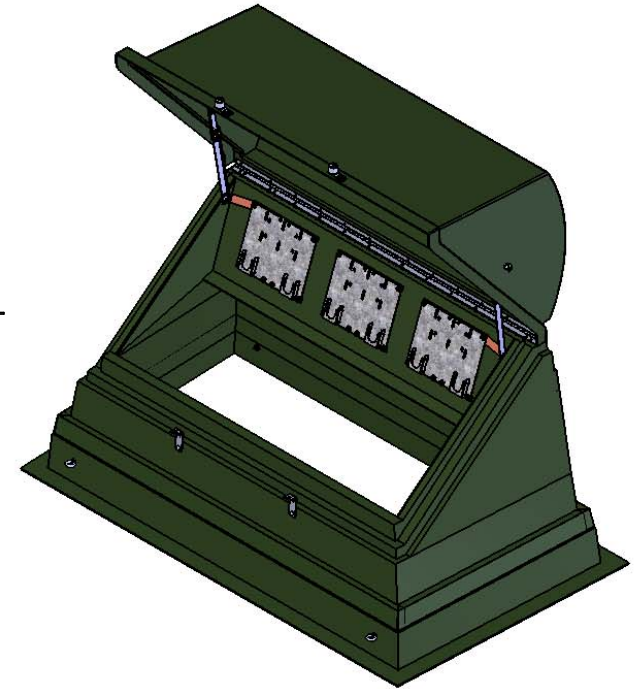
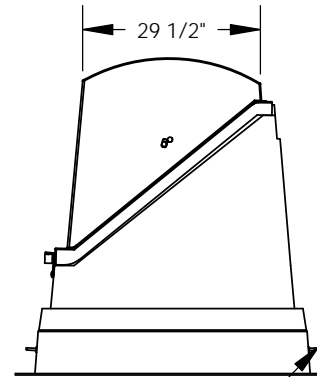
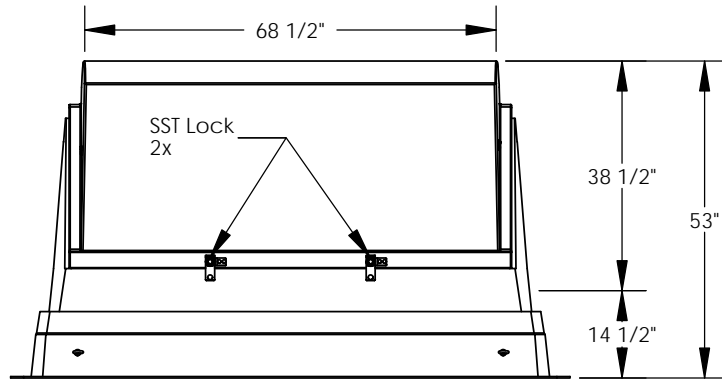

## Nordic Fiberglass, Inc.

21415 US Hwy 75 NW, Warren, MN 56762  
www.nordicfiberglass.com  
218-745-5095 ph. --- 218-745-4990 fax

ND-430-MG-101-X-X

**PROPRIETARY AND CONFIDENTIAL**  
THE INFORMATION CONTAINED IN THIS DRAWING IS THE SOLE PROPERTY OF NORDIC FIBERGLASS, INC. ANY REPRODUCTION IN PART OR AS A WHOLE WITHOUT THE WRITTEN PERMISSION OF NORDIC FIBERGLASS, INC. IS PROHIBITED.

Customer Name: N/A		
DIMENSIONS ARE IN INCHES		
TOLERANCES: ANGLES ± 1°		
FRACTIONAL ± 1/32		
ONE PLACE DECIMAL ±.060		
TWO PLACE DECIMAL ±.030		
THREE PLACE DECIMAL ±.015		
MATERIAL		
DRAWN	NAME	DATE
	P.J.W.	12/08/06
CHECKED	---	--/--/--

SIZE	ITEM ID:	REV.
<b>A</b>	02940.00	<b>REL-01</b>
SCALE:1:32	SHEET 1 OF 1	