

REVISIONS			
REV.	DESCRIPTION	DATE	APPROVED
REL-01		6/28/2006	
REL-02	Added 4x4 Reinforcement	12/8/2006	
REL-03	Re-located FN-38's From Upturn Lip, Reduced From Qty. 6 to 4	12/9/2016	R.L.J.

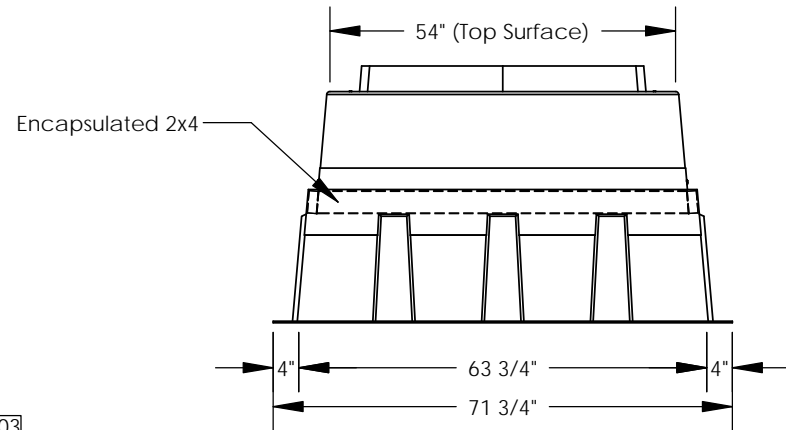
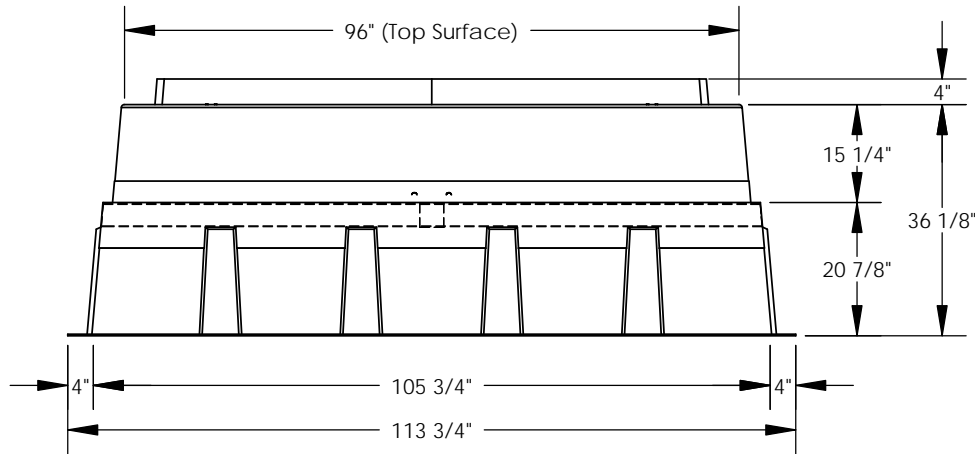
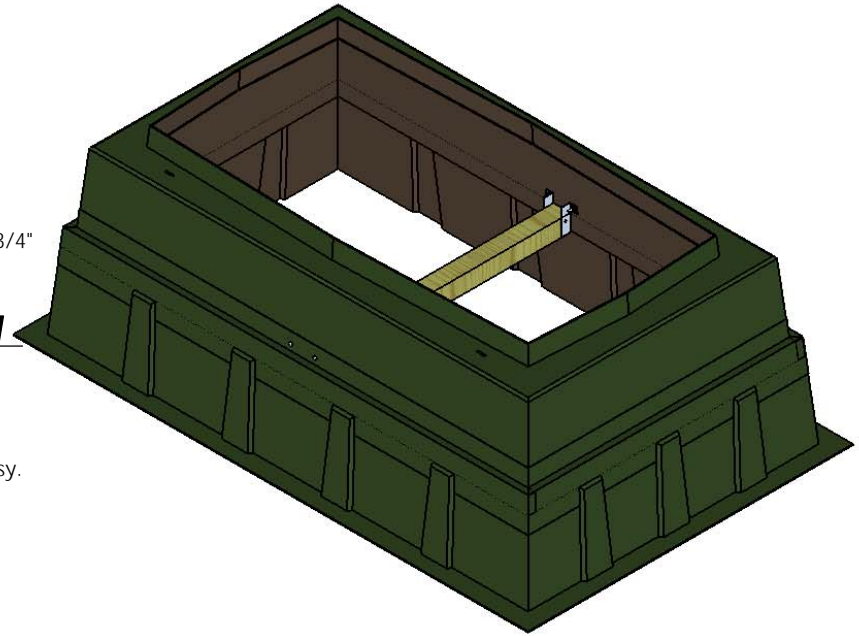
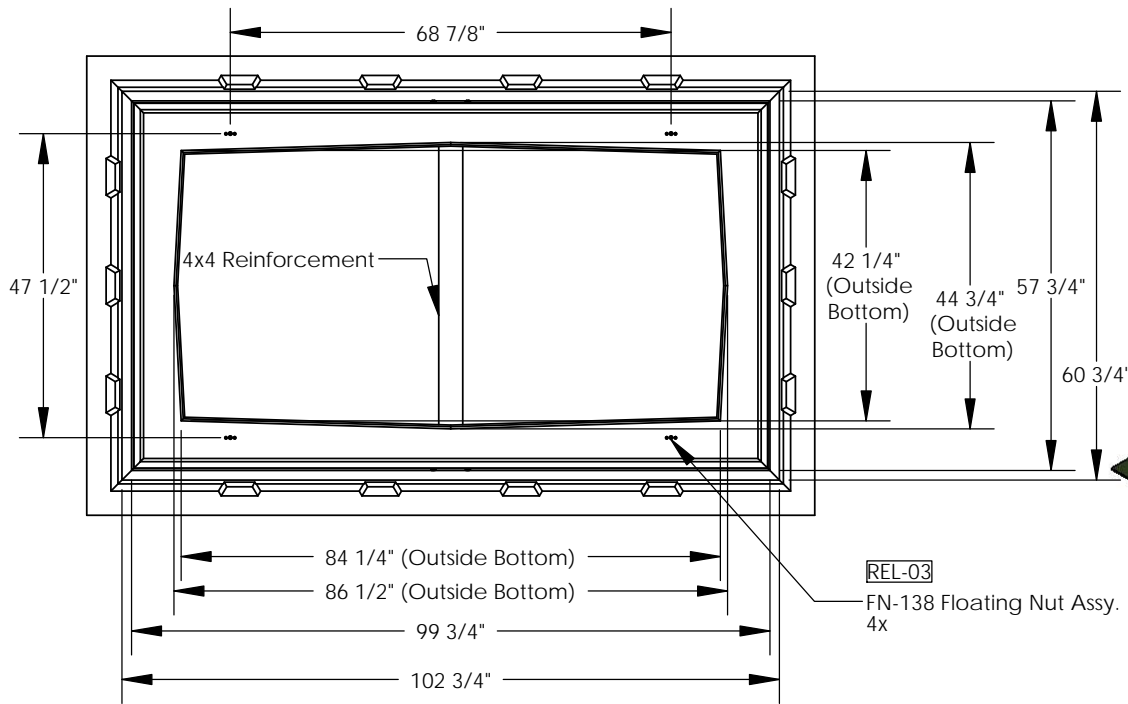

REL-03

Includes:
4 - 3/8"-16x1-1/2" SS HH Bolts
4 - 3/8" Flat Washers

PROPRIETARY AND CONFIDENTIAL
THE INFORMATION CONTAINED IN THIS DRAWING IS THE SOLE PROPERTY OF NORDIC FIBERGLASS, INC. ANY REPRODUCTION IN PART OR AS A WHOLE WITHOUT THE WRITTEN PERMISSION OF NORDIC FIBERGLASS, INC. IS PROHIBITED.

Customer Name: N/A		
DIMENSIONS ARE IN INCHES TOLERANCES: ANGLES ± 1° FRACTIONAL ± 1/2 ONE PLACE DECIMAL ± .060 TWO PLACE DECIMAL ± .030 THREE PLACE DECIMAL ± .015		
MATERIAL		
DRAWN	NAME	DATE
CHECKED	R.L.J.	03/27/06
		--/--

Nordic Fiberglass, Inc.
21415 US Hwy 75 NW, Warren, MN 56762
www.nordicfiberglass.com
218-745-5095 ph. --- 218-745-4990 fax

ND-683054-MG-36EXT

SIZE	ITEM ID:	REV.
A	04062.93	REL-03
SCALE:1:4		SHEET 1 OF 1