

REVISIONS			
REV.	DESCRIPTION	DATE	APPROVED
REL-01		10/11/2006	

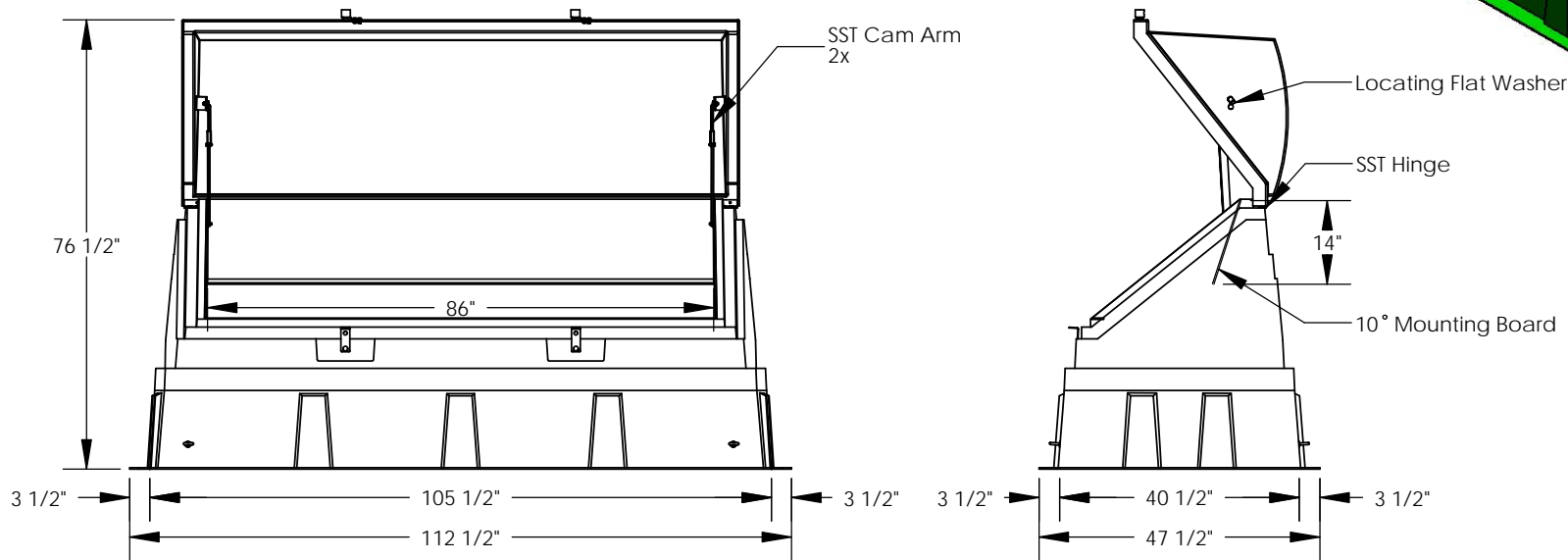
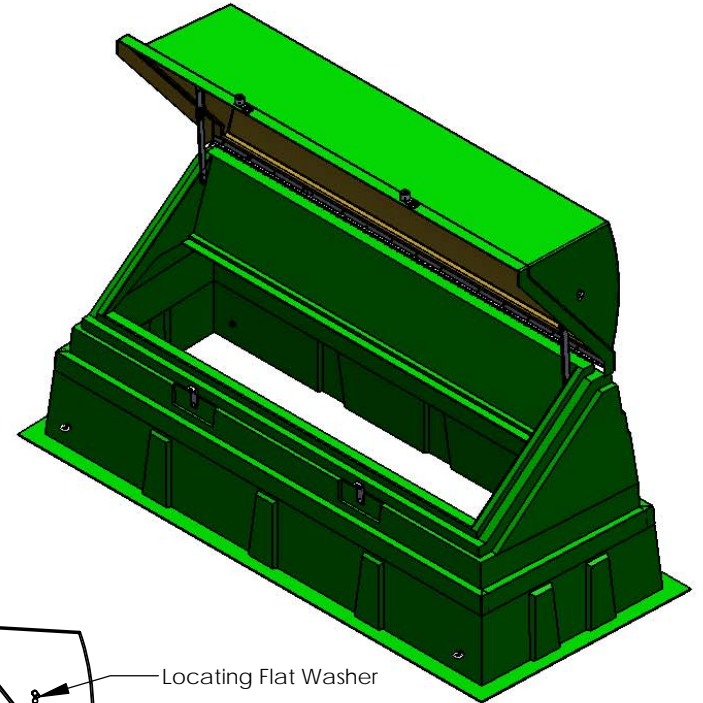
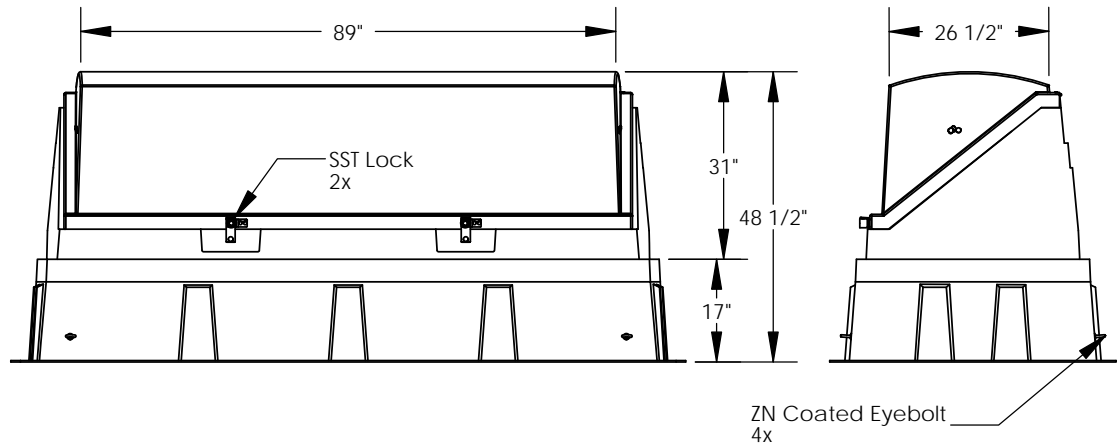

Nordic Fiberglass, Inc.

21415 US Hwy 75 NW, Warren, MN 56762
 www.nordicfiberglass.com
 218-745-5095 ph. --- 218-745-4990 fax

ND-325-MG-X-X-X

PROPRIETARY AND CONFIDENTIAL
 THE INFORMATION CONTAINED IN THIS DRAWING IS THE SOLE PROPERTY OF
 NORDIC FIBERGLASS, INC. ANY REPRODUCTION IN PART OR AS A WHOLE
 WITHOUT THE WRITTEN PERMISSION OF NORDIC FIBERGLASS, INC. IS PROHIBITED.

Customer Name: N/A		
DIMENSIONS ARE IN INCHES		
TOLERANCES: ANGLES ± 1°		
FRACTIONAL ± 1/32		
ONE PLACE DECIMAL ±.060		
TWO PLACE DECIMAL ±.030		
THREE PLACE DECIMAL ±.015		
MATERIAL		
DRAWN	NAME	DATE
	P.J.W.	10/11/06
CHECKED	---	--/--/--

SIZE	ITEM ID:	REV.
A	02790.03	REL-01
SCALE:1:32	SHEET 1 OF 1	