

REVISIONS			
REV.	DESCRIPTION	DATE	APPROVED
REL-01		3/29/2006	

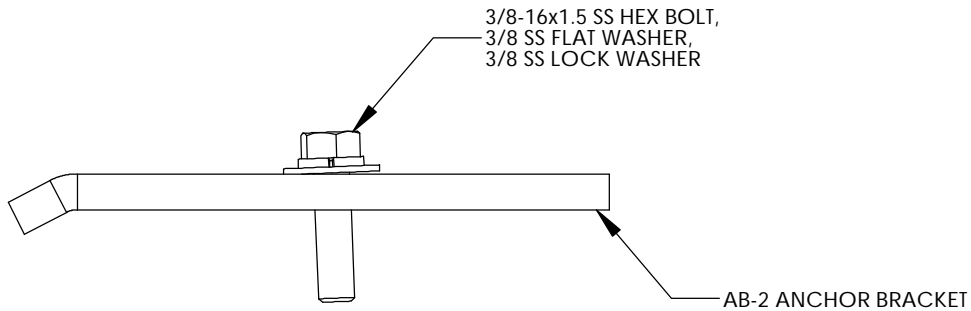
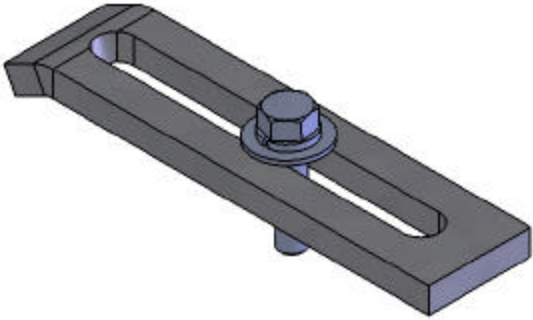
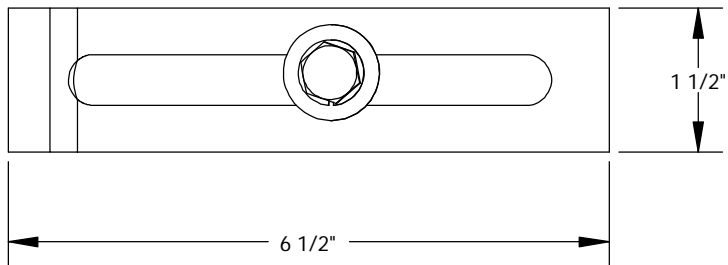

**Nordic Fiberglass, Inc.**

21415 US Hwy 75 NW, Warren, MN 56762  
 www.nordicfiberglass.com  
 218-745-5095 ph. --- 218-745-4990 fax

**AB-2 ANCHOR BRACKET w/ HARDWARE**

**PROPRIETARY AND CONFIDENTIAL**  
 THE INFORMATION CONTAINED IN THIS DRAWING IS THE SOLE PROPERTY OF NORDIC FIBERGLASS, INC. ANY REPRODUCTION IN PART OR AS A WHOLE WITHOUT THE WRITTEN PERMISSION OF NORDIC FIBERGLASS, INC. IS PROHIBITED.

Customer Name: N/A			MATERIAL		SIZE	ITEM ID:	REV.
DIMENSIONS ARE IN INCHES TOLERANCES: ANGLES ± 1° FRACTIONAL ± 1/2 ONE PLACE DECIMAL ±.060 TWO PLACE DECIMAL ±.030 THREE PLACE DECIMAL ±.015			NAME	DATE	<b>A</b>	<b>03235.00</b>	<b>REL-01</b>
DRAWN	P.J.W.	03/29/06	CHECKED	---	---/---/---	SCALE:1:2	WEIGHT: 0.805
						SHEET 1 OF 1	