

REVISIONS			
REV.	DESCRIPTION	DATE	APPROVED

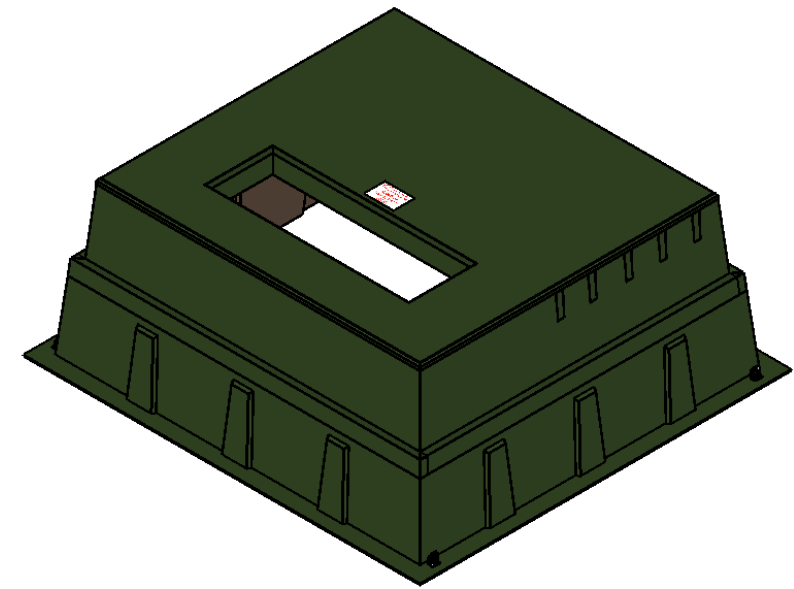

9K Rated Label
 *BOX PAD IS RATED FOR 9,000 LBS.
 FOR HEAVIER TRANSFORMERS SUBMIT
 FOOTPRINT FOR FACTORY REVIEW*
 (1x)

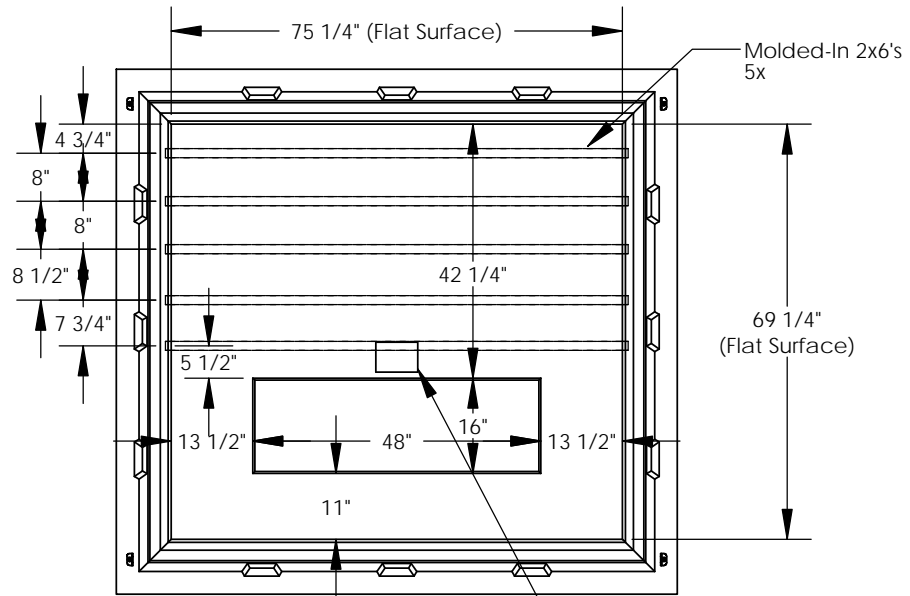
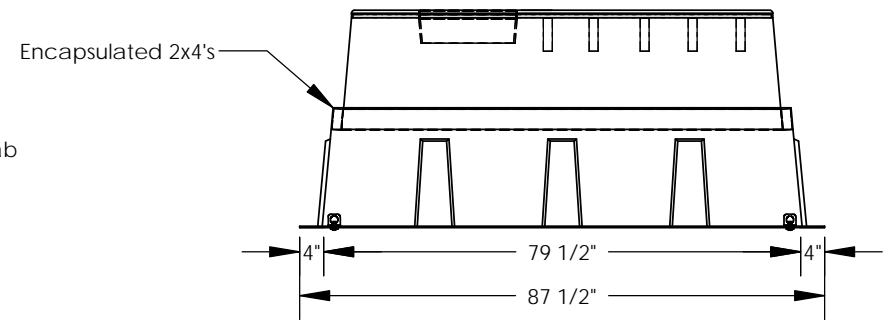
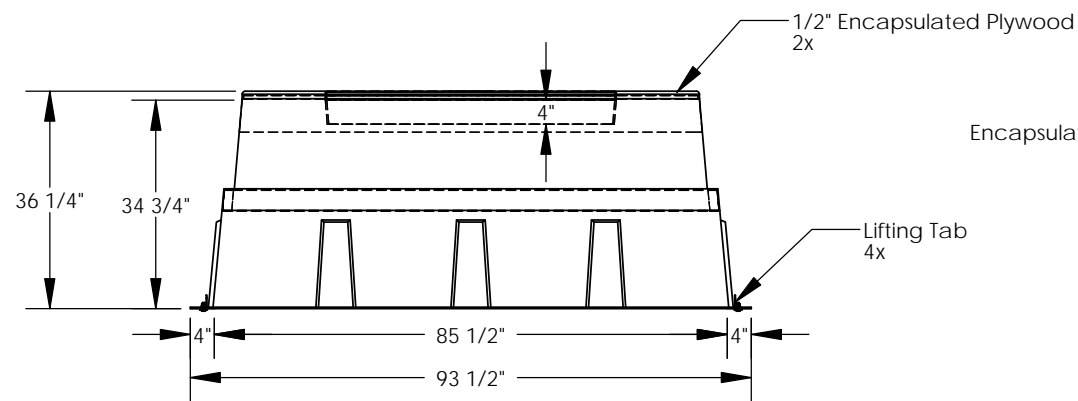

Proper installation of a box pad for transformers over 9,000 lbs. requires the soil to have a compaction level of 98% prior to setting the box pad. If that is not Achievable, a cement pad/footing must be poured underneath the box pad prior to installation.

Nordic Fiberglass, Inc.

21415 US Hwy 75 NW, Warren, MN 56762
 www.nordicfiberglass.com
 218-745-5095 ph. --- 218-745-4990 fax

GS-75-69-36RT-9K-MG-48x16

PROPRIETARY AND CONFIDENTIAL
 THE INFORMATION CONTAINED IN THIS DRAWING IS THE SOLE PROPERTY OF NORDIC FIBERGLASS, INC. ANY REPRODUCTION IN PART OR AS A WHOLE WITHOUT THE WRITTEN PERMISSION OF NORDIC FIBERGLASS, INC. IS PROHIBITED.

Customer Name: N/A		
DIMENSIONS ARE IN INCHES		
TOLERANCES: ANGLES ± 1°		
FRACTIONAL ± 1/2		
ONE PLACE DECIMAL ±.060		
TWO PLACE DECIMAL ±.030		
THREE PLACE DECIMAL ±.015		
MATERIAL		DATE
DRAWN	R.L.J.	08/04/14
CHECKED	---	--/--

SIZE	ITEM ID:	REV.
A	01774.00	REL-01
SCALE:1:32	WEIGHT:	SHEET 1 OF 1