

REVISIONS			
REV.	DESCRIPTION	DATE	APPROVED
REL-02	Updated Description, Opening, Added Lifting Tabs	10/20/2014	R.L.J.

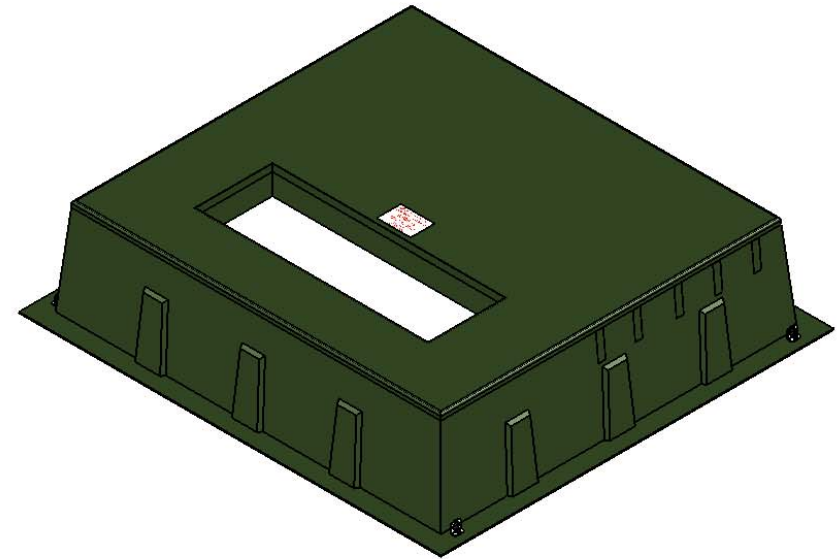

9K Rated Label  
 "BOX PAD IS RATED FOR 9,000 LBS.  
 FOR HEAVIER TRANSFORMERS SUBMIT  
 FOOTPRINT FOR FACTORY REVIEW"  
 (1x)

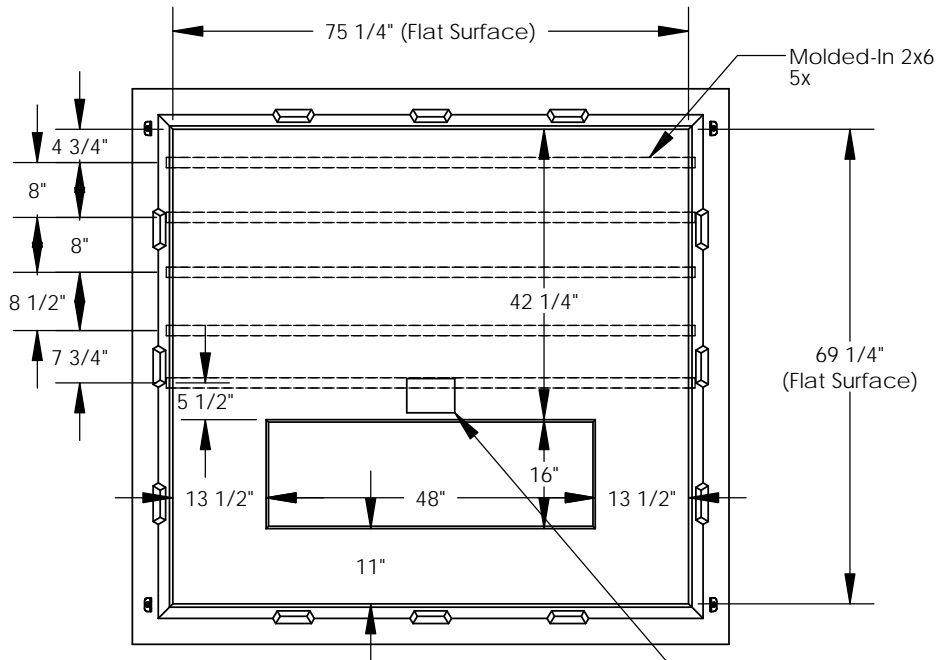
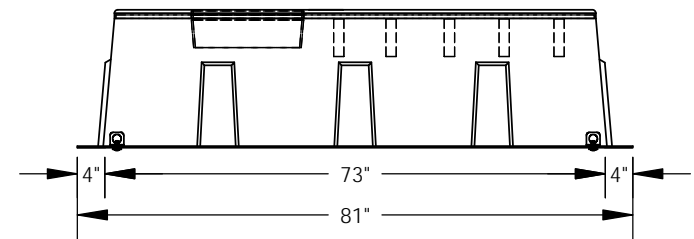
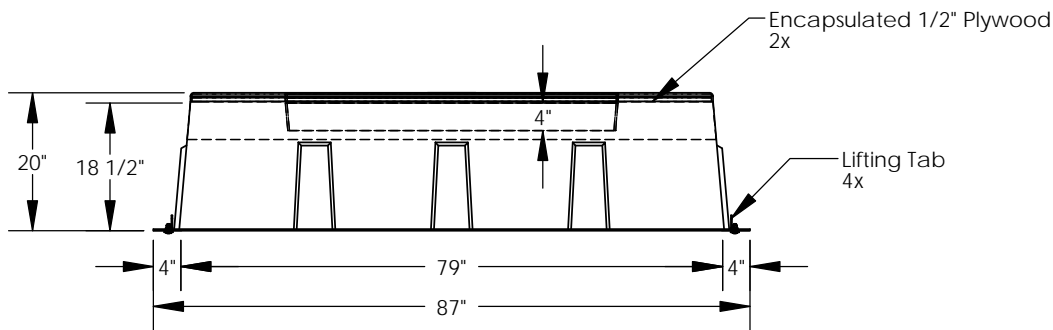

Proper installation of a box pad for transformers over 9,000 lbs. requires the soil to have a compaction level of 98% prior to setting the box pad. If that is not Achievable, a cement pad/footing must be poured underneath the box pad prior to installation.

PROPRIETARY AND CONFIDENTIAL  
 THE INFORMATION CONTAINED IN THIS DRAWING IS THE SOLE PROPERTY OF NORDIC FIBERGLASS, INC. ANY REPRODUCTION IN PART OR AS A WHOLE WITHOUT THE WRITTEN PERMISSION OF NORDIC FIBERGLASS, INC. IS PROHIBITED.

Customer Name: N/A		
DIMENSIONS ARE IN INCHES		
TOLERANCES: ANGLES ± 1°		
FRACTIONAL ± 1/32		
ONE PLACE DECIMAL ±.060		
TWO PLACE DECIMAL ±.030		
THREE PLACE DECIMAL ±.015		
MATERIAL		
DRAWN	NAME	DATE
CHECKED	R.L.J.	06/12/14

**Nordic Fiberglass, Inc.**  
 21415 US Hwy 75 NW, Warren, MN 56762  
 www.nordicfiberglass.com  
 218-745-5095 ph. --- 218-745-4990 fax

GS-75-69-18RT-9K-MG-48x16

SIZE	ITEM ID:	REV.
<b>A</b>	01774.01	<b>REL-02</b>
SCALE:1:32	WEIGHT:	SHEET 1 OF 1