

ITEM	QTY	DESCRIPTION	PART NUMBER	MATERIAL
1	1	VST-175 I.G. @ 1.9 S.G.	1039-03070T-00-xx	PE
2	1	6.0" [152 MM] THREADED NECK	9799-000009-00-00	00 MDPE
3	1	6" SCREW CAP GASKET	9707-056000-00-65	65 EPDM
4	1	6" SCREW CAP	9707-016000-80-10	10 HDPE

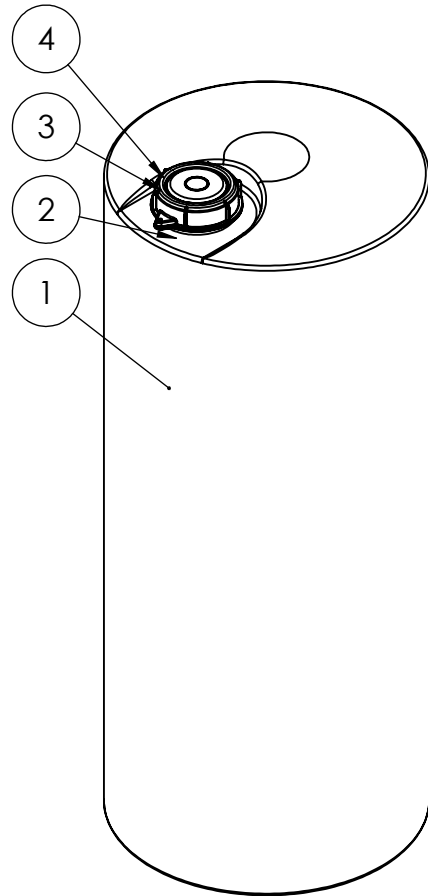
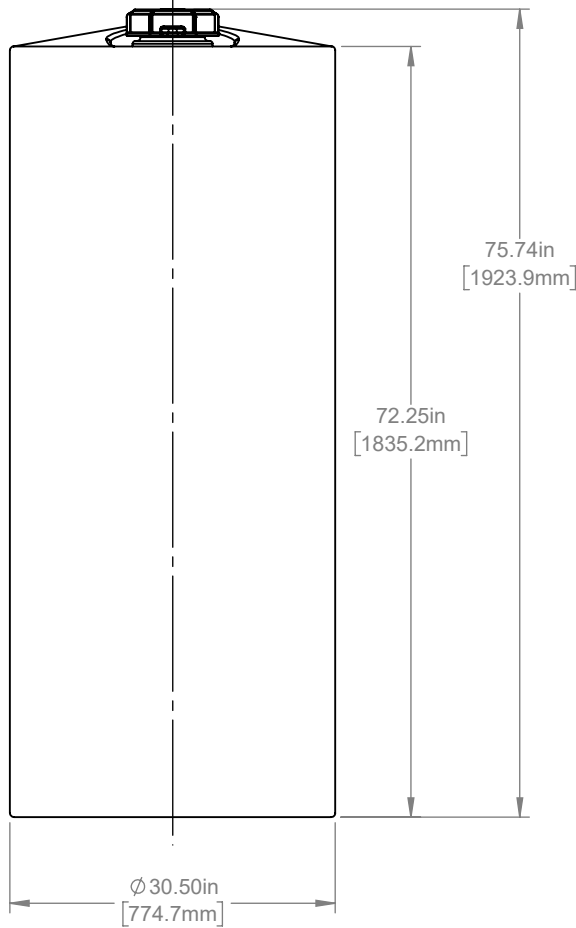
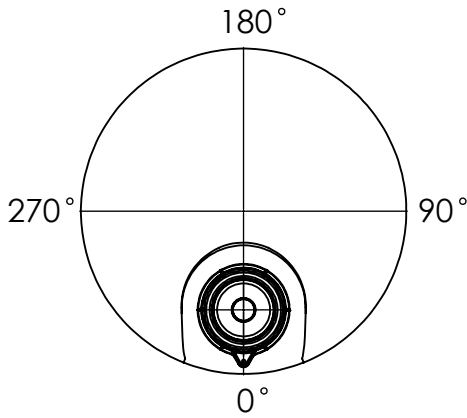

NOTES:

- 1) REFER TO PLAN VIEW FOR FITTING ORIENTATION
- 2) ALL TRIMMED EDGES ARE ROUNDED OFF
- 3) ALL DIMENSIONS ARE APPROXIMATE
- 4) CAPACITY 175 IG (210 USG/790 L)

FAILURE TO PROVIDE ADEQUATE PROVISIONS FOR TANK EXPANSION/CONTRACTION AT FITTINGS WILL VOID ALL WARRANTIES.

****TANK AVAILABLE IN 00 MDPE OR 10 HDPE****

REVISIONS		
REV.	DESCRIPTION	DATE
02	SM - REMOVED FITTING FLAT	2019-09-16
03	SM - REMOVED FITTING FLAT	2019-09-16

Final Approved Drawing Customer:..... Date:.....



RTS PLASTICS
 1027 Industrial Place,
 St. Clements, Ontario, Canada
 T:800-663-2803 F: 519-699-0027
 2900 Industrial Park Drive,
 Austinburg, Ohio, U.S.A.
 T:888-641-3077 F:440-275-3080

Tolerances Unless Otherwise Stated: x.x ±3% x.xx ±2% x.xxx ±1% angular ±3%

Title: **VST-175 I.G. @ 1.9 S.G.**

Part Number: **1039-13070A-00-xx** Revision: **03**
 Customer: **RTS COMPANIES INC.** Project: **VST**
 Drawn By: **DTH** Date: **Mar 17, 2016**
 Material: **PE** Weight: **---**