

Submittal Data Sheet

LineBrace TKL Series Stress Relieving, No Braze Pipe Support for Vertical Lineset Risers in VRF/VRV Air Conditioning Systems

Project Information:

Job Name: _____
 Location: _____
 Engineer: _____
 Submitted to: _____
 For: Reference Approval Construction
 Submitted by: _____
 Reference: _____

Submittal Information:

Approval: _____
 Date: _____
 Construction: _____
 Unit #: _____
 Drawing #: _____

(Section 1) Product Specifications

Application Vertical Lineset Risers in VRF/VRV Air Conditioning Systems

Material Pipe Support Clamp: Type 304 Stainless Steel
 Clamp Liner Plates: Polypropylene
 Hex Nuts and Bolts: M8 Stainless Steel
 Mounting Brackets: 1/8" Hot Dip Galvanized and Powder Coated Steel
 Insulation Sleeve: Expanded 3/4" Polyethylene Foam with a Textured Polyethylene Surface

Size Range 3/8" to 15/8"

(Figure 1) Product Image:

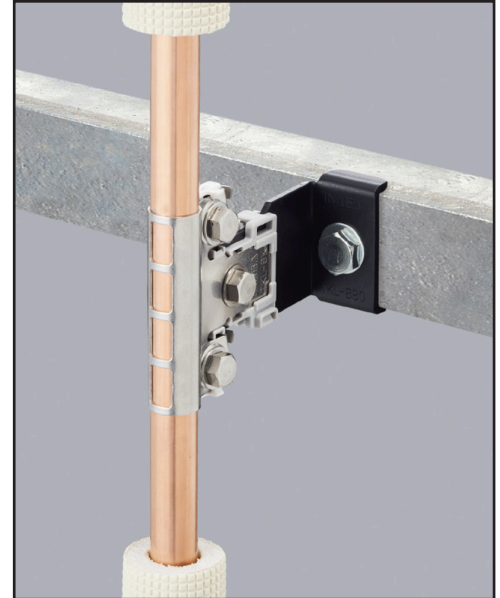

Mounting Bracket Options



(Figure 2) TKL-U
Vertical Mount Bracket for Structural Steel



(Figure 3) TKL-K
Direct Mount Horizontal Wall Bracket



(Figure 4) TKL-B
Universal Horizontal Bracket

(Figure 5) Insulation Sleeve (Mandatory)

for TKL-3K, -4K & -5K



for TKL-6K, -7K, -9K, -11K & -13K



(Figure 6) Load Capacity

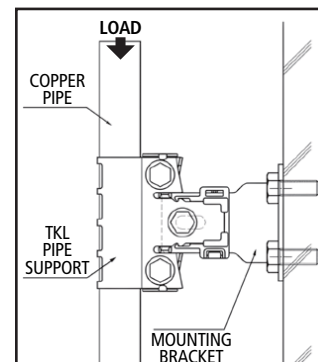

ITEM NO.	LBS.
TKL-3K	169
TKL-4K	183
TKL-5K	319
TKL-6K	339
TKL-7K	368
TKL-9K	449
TKL-11K	542
TKL-13K	652

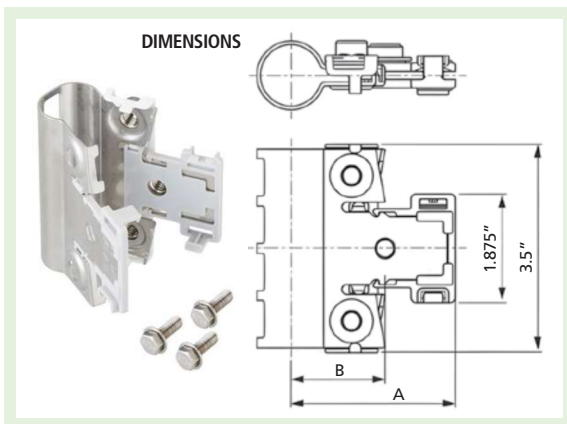

ITEM NO.	COMPLIANT PIPE SIZE	A	B
TKL-3K	Ø 3/8"	2 3/8"	1 1/4"
TKL-4K	Ø 1/2"	2 1/2"	1 3/8"
TKL-5K	Ø 5/8"	2 1/2"	1 3/8"
TKL-6K	Ø 3/4"	2 5/8"	1 1/2"
TKL-7K	Ø 7/8"	2 5/8"	1 1/2"
TKL-9K	Ø 1 1/8"	2 7/8"	1 5/8"
TKL-11K	Ø 1 3/8"	2 7/8"	1 3/4"
TKL-13K	Ø 1 5/8"	3 1/8"	2"