

Submittal Data Sheet

Pipe Prop[®] RUB-USPP Adjustable Pipe and Duct Support System for Commercial Rooftops

Project Information:

Job Name: _____

Location: _____

Engineer: _____

Submitted to: _____

For: Reference Approval Construction

Submitted by: _____

Reference: _____

Submittal Information:

Approval: _____

Date: _____

Construction: _____

Unit #: _____

Drawing #: _____

(Section 1) Product Specifications:

MATERIAL

Pipe Prop RUB-USPP is made of durable recycled crumb rubber.

DIMENSIONS & STRENGTH

Pipe Prop RUB-USPP base is 8"x8"x2" high.

At a 3 1/2" height, Pipe Prop withstands loads ranging from 2,130 lbs at 140°F to 3,935 lbs at 140°F.

WEIGHT

Pipe Prop RUB-USPP weighs 2.5 lbs per unit.

(Section 2) Installation Requirements:

PARTS & MATERIAL

- Pipe Prop RUB-USPP Base
- USPP Saddle and Self-Locking Straps
- 3/4-inch Schedule 40 PVC electrical conduit
- PVC glue
- PVC pipe cutter (ratchet-style recommended)

(Figure 1) Product Image:



(Section 3) Maximum Load Per Pipe Prop Support

HEIGHT	WEIGHT CAPACITY @ 105° F
2.5" (MINIMUM)	3122 LBS
18" (MAXIMUM)	2175 LBS

(Section 4) Pipe Prop RUB-USPP Configurations for Support of RD Series Lineset Ducting System

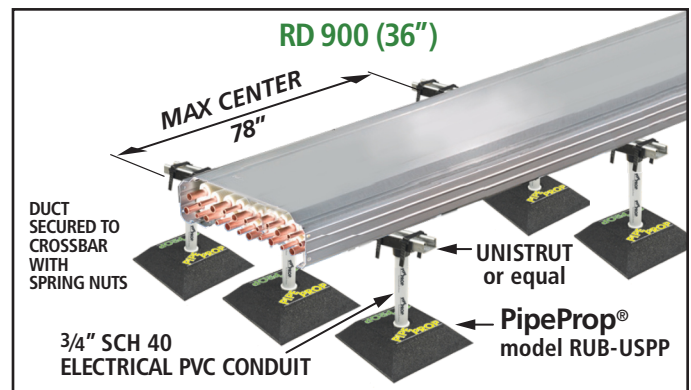
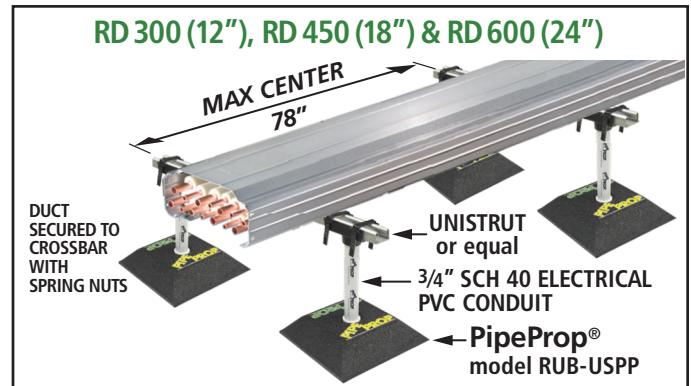

(Figure 2) Dimensional and Assembly Diagrams:

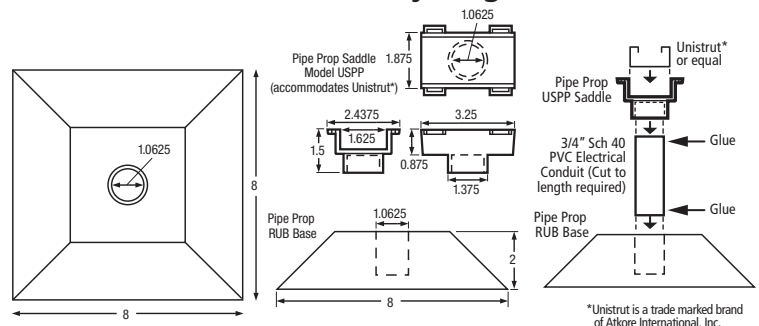

*Unistrut is a trade marked brand of Atkore International, Inc.