

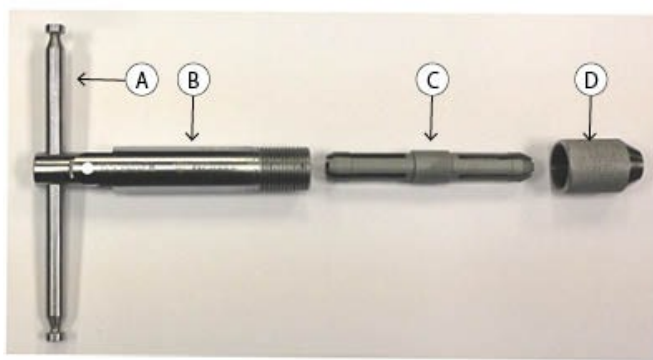

Cam Lock Tap Wrench

	<p>New Patented Design Cam-Lock action prevents tap from loosening during use Large tap range achieved by reversible double ended collet system Tap Capacity: Metric M3 – M12 (Inch 1/8 – 1/2 inch) Heavy duty design Handles high torque usage</p> <p>Can also be used as hand drill for sizes 2 – 8mm (5/64” – 5/16”)</p>
---	--

	<p>A: T-Handle B: Body C: Double Ended Collet D: Nut</p> <p>Double ended collet is reversible and will accept taps from M3 to M12 & 1/8 – 1/2 inch</p>
---	---

	<p>Operation:</p> <p>Position the T-Handle parallel to the Body Remove the Nut and ensure that the collet is positioned to suit the tap size to be used With the Nut loose, install the tap and finger tighten the Nut Reposition the Handle 90 degrees to the Body, now the cam has locked the tap securely in place To remove the tap, turn the T-Handle parallel to the Body and the tap is released</p>
---	---

Linear Code	Description	Weight g	W mm	H mm	L mm
4300-350	Cam Lock Tap Wrench: Capacity 3 – 12mm	437	130	27	130