

Double Burr

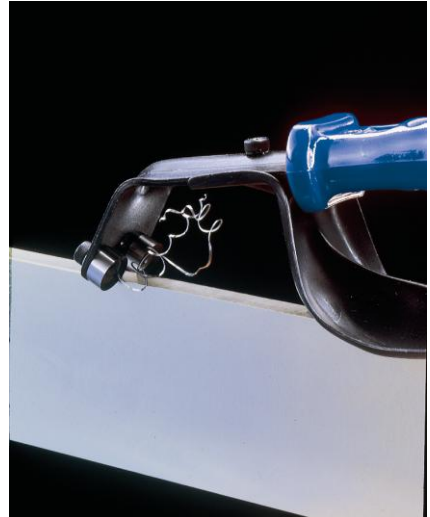

	<p>Dual blade setup simultaneously removes burrs from both sides of sheet metal. Single blade setup removes burr from corner edges Double Burr Handle incorporates safety guard to protect operators hand Unique round cutting blades can be rotated and reversed to provide long blade life Can be set to deburr sheet widths from 0-12mm Supplied with 2 x N80 Blades</p>
---	--

Packed Weight and Dimensions

Code	Description	Weight g	W mm	H mm	L mm
DB 1000	Double Burr	199	62	53	200

	<p>Instructions</p> <p>Do not use heavy pressure when deburring as this will cause the blade to dig into the material and give an uneven finish Use light and even pressure which will allow the blade and handle to work together to remove the burr and leave a smooth finish on the component</p> <p>Blades should be handled carefully as they are sharp and can cut Blades can break causing flying objects Sharp edges and flying objects can cause injury Users and bystanders should wear protective safety glasses Do not pry or bend blades Keep blades and sharp tools away from children Do not regrind blades as this will weaken the blade and cause breakage and possible injury</p> <p>All Noga products meet the strict requirements of ISO 9001 and ISO 14001</p>
---	---

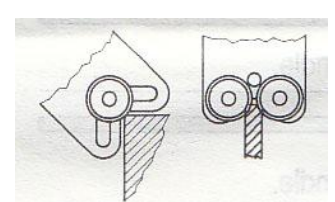
N80 Blades



 <p>Single Blade for Corner Deburring 2 Blades for Double Edge Deburring</p>		<p>Replacement Blade for the Double Burr Tool (DB 1000) Unique round cutting blades can be rotated and reversed to provide long blade life Can be set to deburr sheet widths from 0-12mm Blade material: HSS M2 Blade hardness: 62-64 HRC Fits direct to Double Burr</p>
---	---	---

Packed Weight and Dimensions

Code	Description	Pack Quantity	Weight g	W mm	H mm	L mm
BN8010	Double Burr Blade HSS M2	10	34	62	8	130

Double Burr

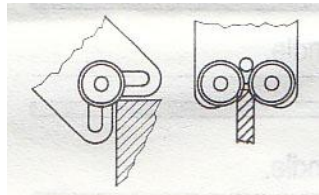
N80 M42 Blade

 <p>Single Blade for Corner Deburring 2 Blades for Double Edge Deburring</p>		<p>Replacement Blade for the Double Burr Tool (DB 1000) Unique round cutting blades can be rotated and reversed to provide long blade life Suitable for use on stainless steel Can be set to deburr sheet widths from 0-12mm Blade material: HSS M42 Blade hardness: 65-67 HRC Fits direct to Double Burr</p>
--	---	---

Packed Weight and Dimensions

Code	Description	Pack Quantity	Weight g	W mm	H mm	L mm
BN8043	Double Burr Blade HSS M42	10	26	62	8	130