

Turning Tools: Carbide Brazed Tipped: Internal Threading: ISO 13

 <p style="text-align: center;">RIGHT HAND SHOWN</p>	<p>Carbide Tipped Brazed Internal Threading Tools          60 Degrees for Metric and Unified Threads          ISO 13          DIN283</p> <p>Grade P30, suitable for machining steel in low to moderate cutting speeds</p>
---	---

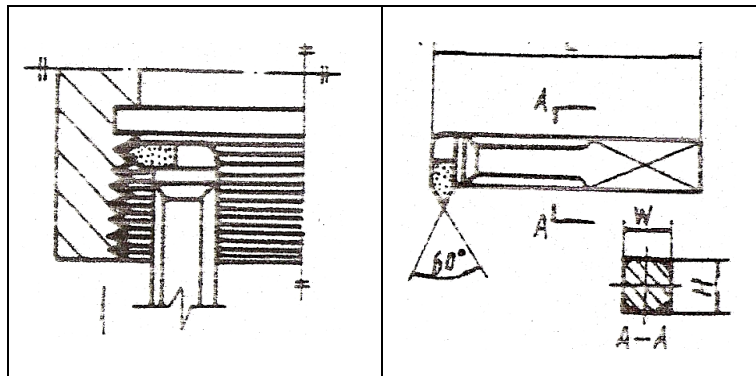

Linear Code	Size mm H	Size mm W	Size mm L	Cutting	Material Grade
29-878-452	10	10	150	R/H	P30
29-878-456	12	12	180	R/H	P30
29-878-460	16	16	210	R/H	P30
29-878-464	20	20	250	R/H	P30
29-878-470	25	25	300	R/H	P30

Packed Weight and Dimensions

Linear Code	Weight	W	H	L
29-878-452	106	37	24	158
29-878-456	196	37	24	192
29-878-460	400	37	24	224
29-878-464	641	37	24	268
29-878-470	1162	43	30	320