

Milling Vice with Swivel Base



Heavy duty precision milling vice with swivel base.
 Used in milling, shaping and drilling machines.
 Swivel base can be removed to allow use as a standard machine vice.
 Swivel base is marked 360 degrees in 1 degree divisions.
 Parallelism of sliding surface to base 0.04mm / 100mm
 Parallelism of jaws 0.05mm / 100mm

Packed Weight and Dimensions

Code	Description	Weight g	W mm	H mm	L mm
52-873-101	Milling Vice with Swivel Base	9250	145	125	275

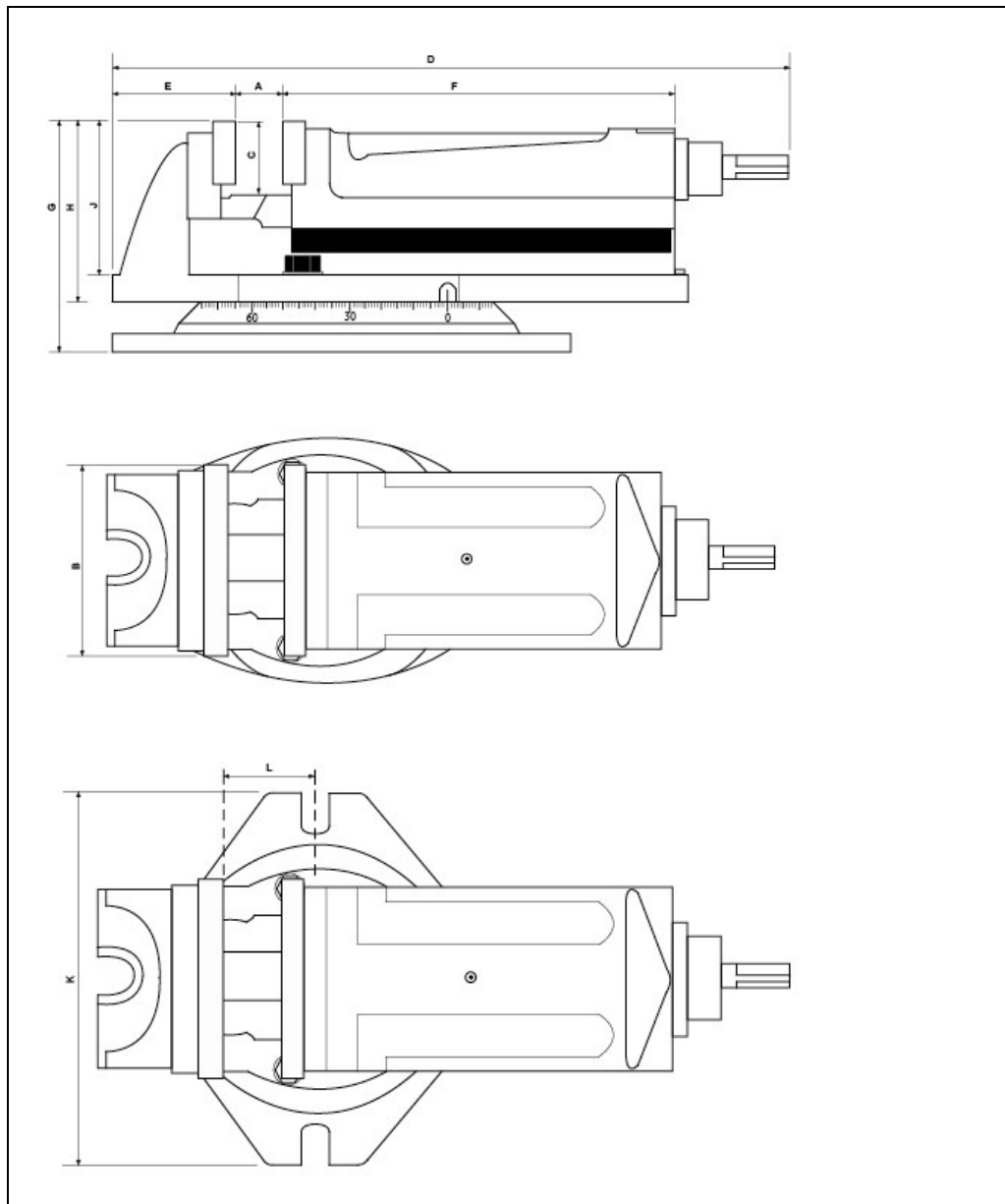

Code	A-Max	B	C	D-Min	D-Max	E	F	G	H	J	K	L	Weight
	mm	mm	mm	mm	mm	mm	mm	mm	mm	mm	mm	mm	Kg
52-873-101	80	100	35	260	345	57	202	108	80	68	190	37	8.7