

Turning Tools: Carbide Brazed Tipped: Inside Corner: ISO 9

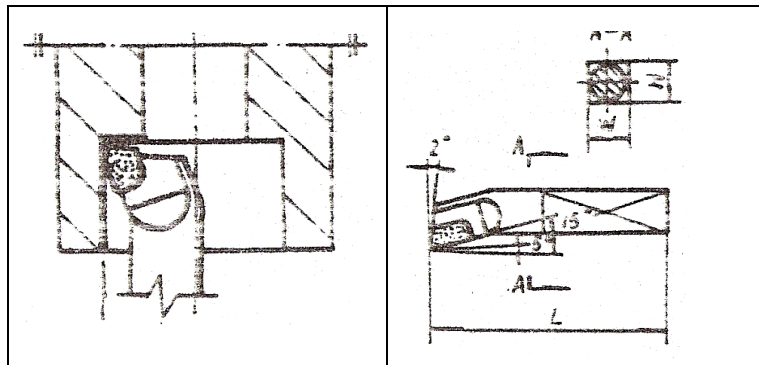
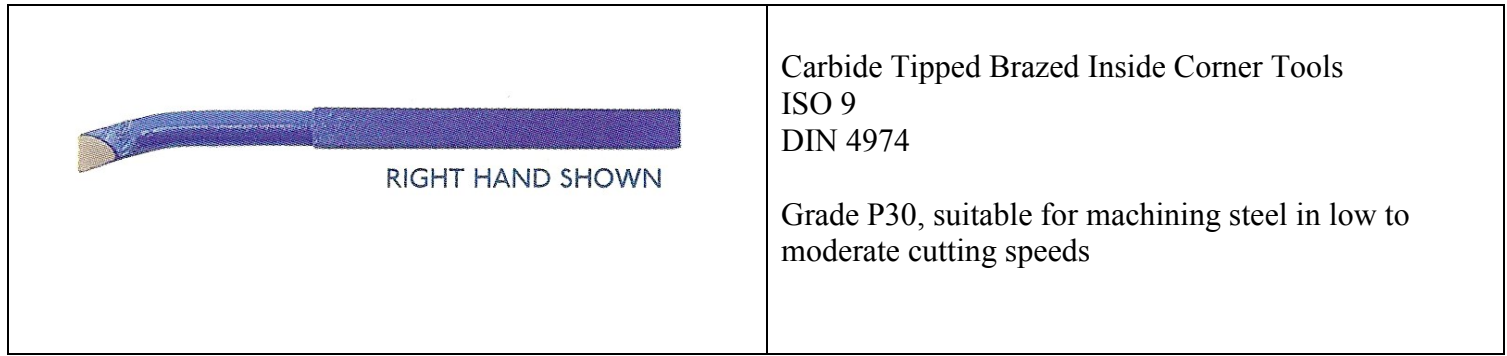

Linear Code	Size mm H	Size mm W	Size mm L	Cutting	Material Grade
29-863-715	8	8	125	R/H	P30
29-863-716	10	10	150	R/H	P30
29-863-717	12	12	180	R/H	P30
29-863-718	16	16	210	R/H	P30
29-863-719	20	20	250	R/H	P30

Packed Weight and Dimensions

Linear Code	Weight g	W mm	H mm	L mm
29-863-715	73	38	16	158
29-863-716	115	34	23	160
29-863-717	186	32	17	193
29-863-718	370	34	23	114
29-863-719	701	34	24	262