

Digital Caliper and Electronic Micrometer Set  
 Set contains:  
 1 x Electronic Caliper: 150mm/6"  
 1 x Electronic Micrometer: 0-25/0-1"mm  
 Housed in a fitted storage case

Packed Weight and Dimensions

Code	Description	Weight g	W mm	H mm	L mm
50-715-150	Electronic Digital Measuring Set	719	140	45	255

Electronic Caliper 49-923-150



Hardened stainless steel frame and measuring jaws  
 Thumbroll adjustment  
 Knurled locking screw  
 Depth rod  
 Clear LCD Display  
 Large 11mm digits  
 Inch/Metric conversion  
 Origin setting  
 Resolution: 0.01mm / 0.0005"  
 Repeatability: 0.01mm / 0.0005"  
 4 Way measurement:  
 Individual serial numbers  
 Power: 1 x Silver oxide battery SR44 - 1.55v  
 Operating temperature: 5 - 40°C  
 Relative humidity: Maximum 80%  
 Warranty: 1 year

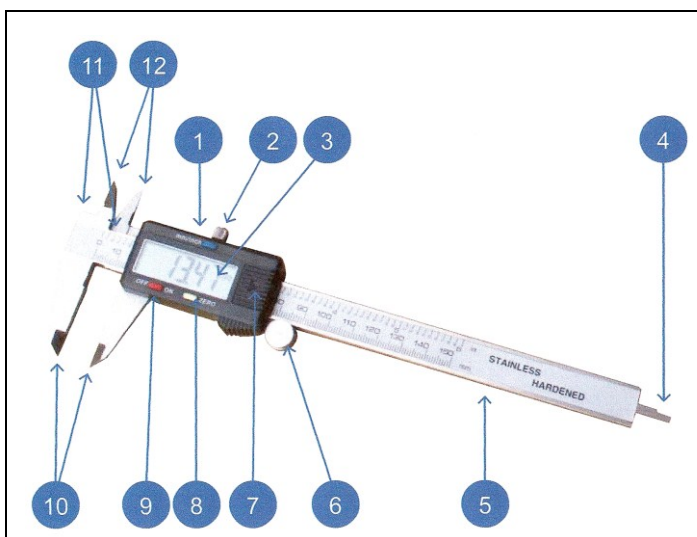

- 1 Metric / Inch Conversion Button
- 2 Knurled Locking Screw
- 3 LCD Display
- 4 Depth Measuring Blade
- 5 Caliper Beam
- 6 Thumbroll Fine Adjustment
- 7 Battery Cover
- 8 Zero Set Button
- 9 Power Button ON/OFF
- 10 External Measuring Jaws
- 11 Step Measuring Faces
- 12 Internal Measuring Jaws

Code	Range	Resolution	Repeatability	Accuracy	Ext. Jaw Length	Int. Jaw Length
49-923-150	150mm / 6"	0.01mm / 0.0005"	0.01mm / 0.0005"	±0.03mm	40mm	18mm

Product: Electronic Digital Measuring Set

Page 2 of 5

Electronic Caliper 49-923-150

## OPERATING INSTRUCTIONS

When using the Caliper for the first time or after a period of non-use, wipe the beam scale with a dry clean cloth to remove any condensation or oil deposits.

Prior to setting the caliper for measuring, first clean the measuring faces with a soft clean cloth or paper.

Switch Caliper ON

Move Caliper jaws together.

Select required measuring mode Inch / Metric.

Zero display, caliper is now ready for direct measurement.

Caliper can be zeroed at any position within its range, to provide relative measurements.

Caliper provides 4 way measurements, External, Internal, Step and Depth.

## OPERATING CARE

Clean measuring faces with dry soft cloth

Keep away from strong magnetic fields

Prevent ingress of oil / liquids into electronics

Remove battery if instrument is not used for a long period of time

Do not disassemble or drop the instrument

**Do not mark instrument by engraving, etching or any other permanent marking method, as this will invalidate the warranty**

## FAULT FINDING

Fault	Cause	Action
Display flashes	Battery voltage below 1.45volts	Replace battery
Display frozen	Circuit overload	Remove battery and replace after 4 minutes
Accuracy below specification but within +/- 0.1mm	Dirt in sensor	Remove slider cover assembly, clean face of sensor with dry clean compressed air (5kg/cm <sup>2</sup> )
No display	Poor battery contact	Remove battery and carefully adjust battery contacts, replace battery.
	Dead battery	Replace battery.

Electronic Micrometer 50-715-025



DIN 863/1  
 Clear LCD Display  
 Metric/Inch Conversion  
 Relative & Absolute Modes  
 Resolution 0.001mm/0.0005"  
 Tungsten Carbide Anvils  
 Auto Power Off after 5 minutes  
 Friction Thimble  
 Spindle Lock Lever  
 Plastic Heat Guard  
 Painted Frame  
 Supplied with Ball Anvil Attachment  
 Supplied in fitted case

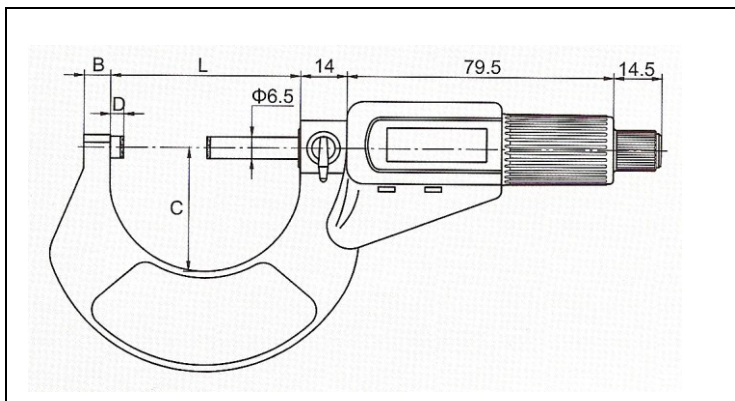

Code	Range mm/Inch	C mm	L mm	B mm	D mm	Accy mm
50-715-025	0-25/0-1"	27.5	32	6	3	0.002

Repeatability: 0.001mm  
 Measuring force: 5 – 10N  
 Operating temperature; 0 to 40° C  
 Relative humidity: Maximum 80%  
 Power: 1 x SR44: 1.5V battery

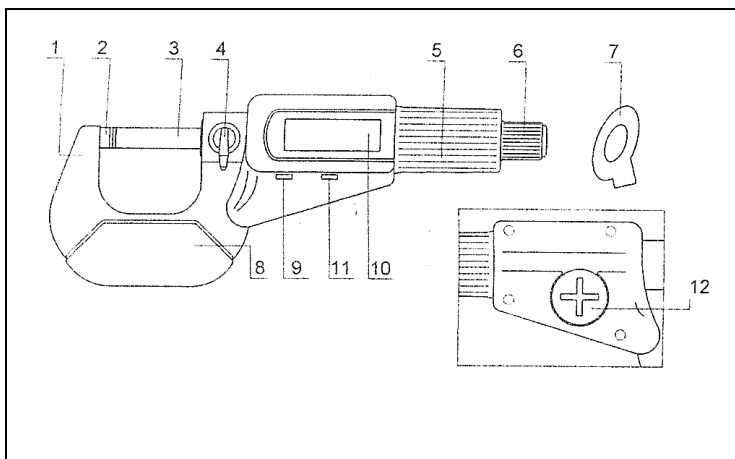

- 1 Frame
- 2 Anvil
- 3 Spindle
- 4 Locking Device
- 5 Ratchet Friction Thimble
- 6 Quick Drive
- 7 Spanner
- 8 Frame Cover
- 9 ON/OFF / SET Button
- 10 LCD Display
- 11 ABS/INC / Unit Button
- 12 Battery Cover

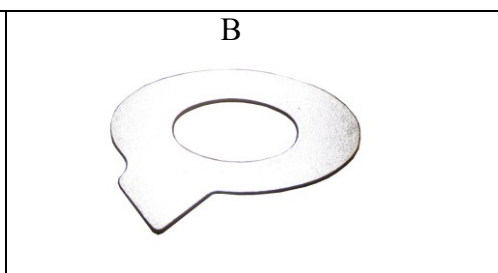
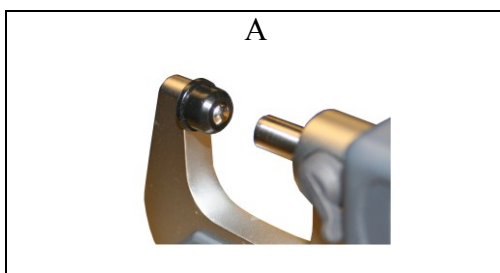

Accessories supplied:

A: Ball Anvil will fit on either the anvil or spindle as required

B: Tool for removing and replacing the battery cover

Product: Electronic Digital Measuring Set

Page 4 of 5

Electronic Micrometer 50-715-025

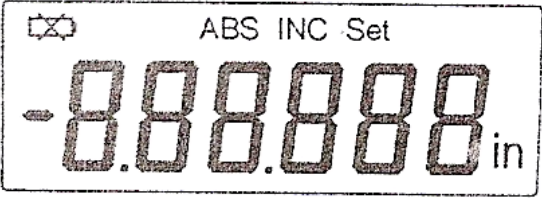
Display options	<input checked="" type="checkbox"/> Battery low voltage indicator ABS Absolute measuring mode INC Relative measuring mode Set Origin set in Inch or metric display
	

### Setting and Use Instructions

Clean micrometer spindle and measuring anvils with soft cloth or paper to remove any oil or particles which may affect the measurements

Ensure that the micrometer is thermally stabilised with the temperature where it is to be used

Ensure that the spindle lock is off

#### Absolute Measurement

Press and release the ON/OFF / SET button to power up the micrometer. (ABS will show on the display)

Choose either inch or metric measuring system by pressing the ABS/INC / UNIT button for 2 seconds (mm or in will show on the display)

Advance the spindle towards the fixed anvil. Use the friction thimble to finally close the 2 anvils together. Rotate the thimble 1 ½ to 2 revolutions to exert a constant measuring force

To zero the micrometer in this position press and hold the ON/OFF / SET button for 2 seconds

The micrometer is now ready to use in Absolute mode

#### Relative Measurement

Press and release the ON/OFF / SET button to power up the micrometer. (ABS will show on the display)

Seat the micrometer anvil and spindle across the desired setting piece using the friction thimble

Press and release the ASBS/INC / UNIT button (INC will show on the display) and the display will show zero

The micrometer is now ready to take measurements and will indicate either + or – variations from the original setting piece size

#### Operating Care

Clean measuring faces with a clean soft cloth only

Do not use any organic solvent for cleaning such as acetone etc.

Keep instrument away from strong magnetic fields and high voltage environments which can affect the correct working of the electronic pack

Prevent the ingress of oil and liquids into the electronics

Do not use or store the micrometer in direct sunlight, or in an excessively hot or cold environment

The Instrument can be turned on by either using the ON/OFF button or simply by turning the thimble

To conserve the battery the instrument should be turned off using the ON/OFF button or it will turn off automatically after 5 minutes of non use

Remove battery if the instrument is not to be used for a long period of time

Do not disassemble or drop the instrument

**Do not mark the instrument by engraving, etching or any other permanent method of marking as this will invalidate the warranty**

Product: Electronic Digital Measuring Set

Page 5 of 5

Electronic Micrometer 50-715-025

## Specifications:

Measuring Force:	5 – 10N
Power Consumption:	Greater than 35 milliamps
Operating Temperature:	0 – 40 deg.C
Storage Temperature:	-20 to 60 deg. C
Protection Class:	IP54 (resistant to water splash)

## Fault Finding

Failure	Causes	Remedy
Display: “E 1”	Measured value is over display range	Reset the origin or change to relative mode
Display: “E 3”	1 The micrometer is disturbed 2 Something wrong with sensor	1 Reset the battery 2 return the micrometer for repair
Measured value is not correct	1 Measuring surfaces are not clean 2 The origin is incorrect	1 Clean measuring surfaces 2 Reset the origin
Display is confused or dead	Strong disturbance to micrometer	Reset battery
No display Display is blurring Battery sign appears	Battery voltage below 1.45V	Replace battery