

Specifications

MODELS	GS™-2032		GS™-2632		GS™-3232	
	Metric	US	Metric	US	Metric	US
Working height maximum*	8.10 m	26 ft	9.92 m	32 ft	11.75 m	38 ft
A Platform height maximum	6.10 m	20 ft	7.92 m	26 ft	9.75 m	32 ft
B Platform height stowed	1.03 m	3 ft 4.5 in	1.16 m	3 ft 9.5 in	1.29 m	4 ft 2.75 in
C Platform length - outside	2.26 m	7 ft 5 in	2.26 m	7 ft 5 in	2.26 m	7 ft 5 in
extended	3.18 m	10 ft 5 in	3.18 m	10 ft 5 in	3.18 m	10 ft 5 in
Slide-out platform extension deck	0.91 m	3 ft	0.91 m	3 ft	0.91 m	3 ft
D Platform width - outside	0.81 m	2 ft 8 in	0.81 m	2 ft 8 in	0.81 m	2 ft 8 in
Guardrail height: fixed rails	0.99 m	3 ft 3 in	—	—	—	—
fold down rails	1.10 m	3 ft 7 in	1.10 m	3 ft 7 in	1.10 m	3 ft 7 in
Toeboard height	0.15 m	6 in	0.15 m	6 in	0.15 m	6 in
E Height - stowed						
fixed rails	2.03 m	6 ft 8 in	—	—	—	—
folding guardrails	2.13 m	7 ft	2.26 m	7 ft 5 in	2.43 m	8 ft
rails folded	1.75 m	5 ft 9 in	1.91 m	6 ft 3 in	2.03 m	6 ft 8 in
F Length - stowed	2.44 m	8 ft	2.44 m	8 ft	2.44 m	8 ft
Length - extended	3.33 m	10 ft 11 in	3.33 m	10 ft 11 in	3.33 m	10 ft 11 in
G Width	0.81 m	2 ft 8 in	0.81 m	2 ft 8 in	0.81 m	2 ft 8 in
H Wheelbase	1.85 m	6 ft 1 in	1.85 m	6 ft 1 in	1.85 m	6 ft 1 in
I Ground clearance - centre	0.09 m	3.5 in	0.09 m	3.5 in	0.09 m	3.5 in
J - with pothole guards deployed	0.02 m	0.75 in	0.02 m	0.75 in	0.02 m	0.75 in

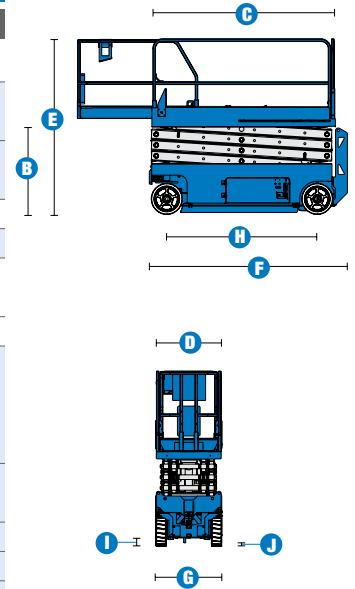

PRODUCTIVITY						
Maximum platform occupancy**						
- indoor	2	2	2	2	2	2
- outdoor	1	1	—	—	—	—
Lift capacity	363 kg	800 lbs	227 kg	500 lbs	227 kg	500 lbs
Extension deck capacity	113 kg	250 lbs	113 kg	250 lbs	113 kg	250 lbs
Drive height	full height	full height	full height	full height	6.71 m	22 ft
Drive speed - stowed	3.5 km/h	2.2 mph	3.5 km/h	2.2 mph	3.5 km/h	2.2 mph
Drive speed - raised	0.8 km/h	0.5 mph	0.8 km/h	0.5 mph	0.8 km/h	0.5 mph
Gradeability - stowed***	30%	30%	25%	25%	25%	25%
Maximum outrigger leveling: front to back	—	—	—	—	—	3°
side to side	—	—	—	—	—	5°
Turning radius - inside	zero	zero	zero	zero	zero	zero
Turning radius - outside	2.13 m	7 ft	2.13 m	7 ft	2.13 m	7 ft
Raise / lower speed	30 / 34 sec	30 / 34 sec	30 / 40 sec	30 / 40 sec	57 / 40 sec	57 / 40 sec
Controls	proportional		proportional		proportional	
Drive	dual front wheel		dual front wheel		dual front wheel	
Multiple disc brakes	dual rear wheel		dual rear wheel		dual rear wheel	
Tyres - solid non-marking	38 x 13 x 28 cm	15 x 5 x 11 in	38 x 13 x 28 cm	15 x 5 x 11 in	38 x 13 x 28 cm	15 x 5 x 11 in

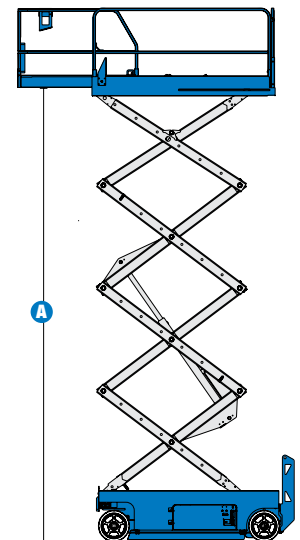

POWER						
Power source	24V DC (four 6V 225 Ah batteries)		24V DC (four 6V 225 Ah batteries)		24V DC (four 6V 225 Ah batteries)	
Hydraulic system capacity	14.2 L	3.75 gal	14.2 L	3.75 gal	14.2 L	3.75 gal

WEIGHT****						
	1,825 kg	4,024 lbs	1,956 kg	4,313 lbs	2,352 kg	5,185 lbs

STANDARDS COMPLIANCE						
	ANSI A92.6, CSA B354.2, CE Compliance, AS 1418.10					

* The metric equivalent of working height adds 2 m to platform height. U.S. adds 6 ft to platform height.
 ** CE/AUS markets: GS-2632 and GS-3232 indoor use only. GS-2032 outdoor use-one person maximum occupancy.
 *** Gradeability applies to driving on slopes. See operator's manual for details regarding slope ratings.
 **** Weight will vary depending on options and/or country standards.

Features

STANDARD FEATURES

MEASUREMENTS

GS™-2032

- 8.10 m (26 ft) working height
- Up to 363 kg (800 lbs) lift capacity

GS™-2632

- 9.92 m (32 ft) working height
- Up to 227 kg (500 lbs) lift capacity

GS™-3232

- 11.75 m (38 ft) working height
- Up to 227 kg (500 lbs) lift capacity

PRODUCTIVITY

- 2.26 m x 0.81 m (7 ft 5 in x 2 ft 8 in) steel platform
- 0.91 m (3 ft) extension deck
- Folding rails with half-height swing gate
- Automatic leveling outriggers (GS-3232 only)
- Dual front wheel drive
- Proportional lift and drive
- Platform control with battery charge indicator and diagnostic display
- Onboard diagnostic system
- Manual platform lowering valve
- Emergency stop at both platform and ground controls
- Multiple disc brakes
- Brake release
- Solid non-marking tyres
- Pothole guards
- Tilt alarm
- Descent alarm
- Electronic horn
- Hour meter
- Dual flashing beacons
- Motion alarm

POWER

- 24 V DC (four 6 V 225 Ah batteries)
- Universal 20 amp smart charger

OPTIONS & ACCESSORIES

PRODUCTIVITY

- Air line to platform
- Panel mounted, recessed charger receptacle
- Platform work lights
- Automotive horn
- Laser locator (GS-3232)

POWER OPTIONS

- Maintenance-free batteries
- EE rating
- 240 V power to platform



Genie Australia – Toll free number 1800 788 633

Brisbane (Head Office)
33 Kimberley Street
Darra QLD 4076

Sydney
74 Glendenning Road
Glendenning NSW 2761

Melbourne
374 Hammond Road
Dandenong VIC 3175

Perth
126 Sheffield Road
Welshpool WA 6106

Genie United States Distributed by:

18340 NE 76th Street
P.O. Box 97030
Redmond, Washington
98073-9730

Effective Date: April 2012. Product specifications and prices are subject to change without notice or obligation. The photographs and/or drawings in this document are for illustrative purposes only. Refer to the appropriate Operators' Manual for instructions on the proper use of this equipment. Failure to follow the Operators Manual when using our equipment or to otherwise act irresponsibly may result in serious injury or death. The only warranty applicable to our equipment is the standard written warranty applicable to the particular product and sale and we make no other warranty, express or implied. Products and services listed may be trademarks, service marks, or trade names of Terex Corporation, Terex South Dakota, Inc., and/or their subsidiaries in the USA and other countries. All rights reserved. Terex is a registered trademark of Terex Corporation in the USA and many other countries. Genie is a registered trademark of Terex South Dakota, Inc. in the USA and many other countries. ©2009 Terex Corporation.