



## Exceptional productivity

- Working height up to 13.8m
- Driveable at full height
- Load capacity: 350 kg
- Robust, reliable, easy to maintain
- Extended platform
- Long working cycles

## Optimum compactness

- 1.2m width
- Folding guardrails





# COMPACT 14



ELECTRIC SCISSOR LIFTS

## TECHNICAL DATA

## COMPACT 14

Working height	13.8 m
Platform height	11.8 m
Lift capacity	350 kg
<b>A</b> Platform length - outside	2.3 m
Platform length - extended	3.22 m
Length - extension	0.92 m
Platform width - outside	1.2 m
<b>D</b> Storage height	2.08 m
<b>C</b> Height - stowed	2.5 m
<b>B</b> Overall width	1.2 m
<b>E</b> Length	2.74 m
<b>F</b> Wheelbase	1.86 m
<b>G</b> Ground clearance - Centre	13 cm
Ground clearance - Pothole guards deployed	2 cm
Drive speed	0.9 - 2.8 km/h
Driveable at full height up to	11.8 m
Gradeability	23 %
Tilt	2° / 3°
Lift / lower speed	68 s / 54 s
Turning radius - outside	2.38 m
Tyres - non marking	15 x 5
Batteries	24 V - 255 Amph (C5)
Hydraulic system capacity	25 l
Weight	3175 kg

350 kg  
770 lbs / 3x

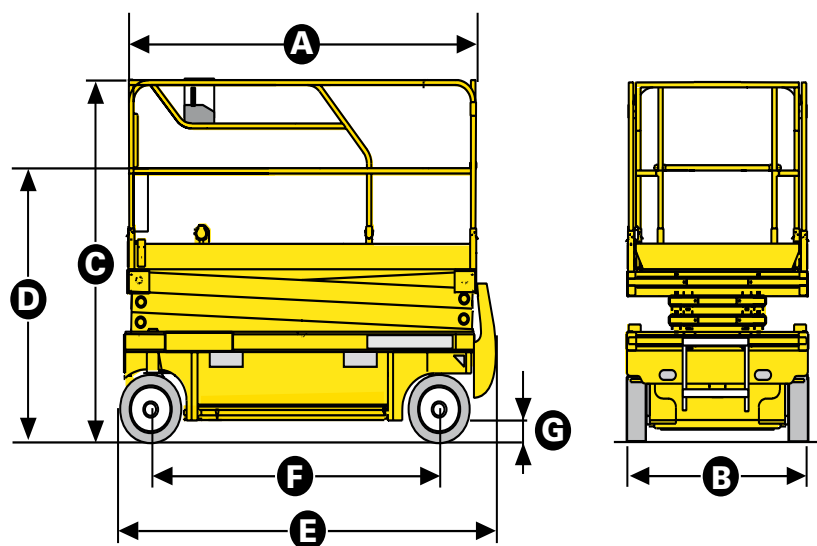
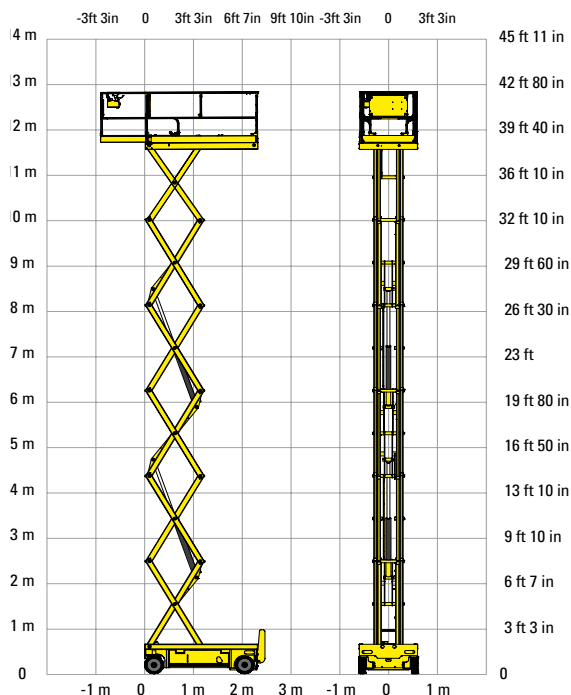

## STANDARD EQUIPMENT

- Pothole guards
- Battery charge indicator
- Proportional lift and drive
- Removable control box in platform
- Swing out component tray
- Battery charger with automatic stop
- Solid non-marking tyres
- Brake release
- Tilt controller
- Load Management System in the platform
- Manual platform lowering valve
- Integrated forklift pockets
- Towing hooks
- Horn
- Hourmeter

## OPTIONS AND ACCESSORIES

- Flashing light
- Travel alarm
- Working light
- Power to platform
- Biodegradable hydraulic oil
- Centralised battery filling

