

DRAWING NO.
C787RPFU

REV
B

Customer Drawing

REVISION HISTORY

REV	DESCRIPTION (ECO)	DATE	APPROVED
A	787RPFU, REPLACES 787RPFX ECN 4798	5/5/11	L.F.
B	ADD DFARS & ROHS COMPLIANT ECO 5669	5/21/13	AK

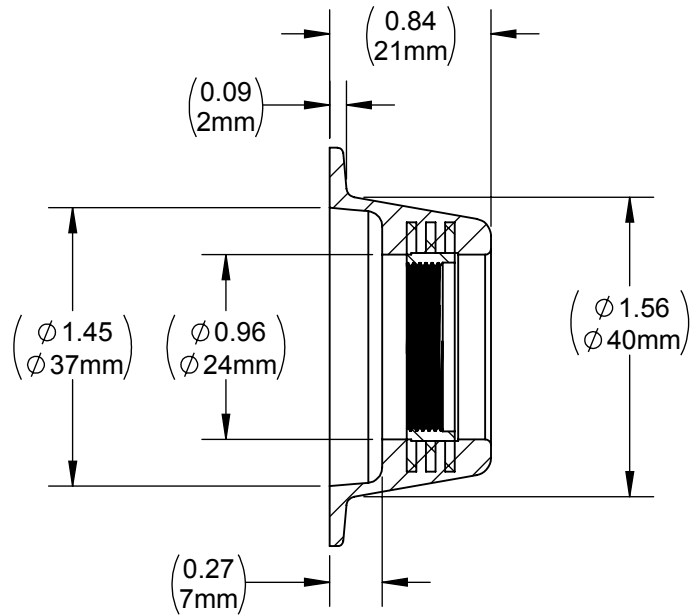

SECTION A-A

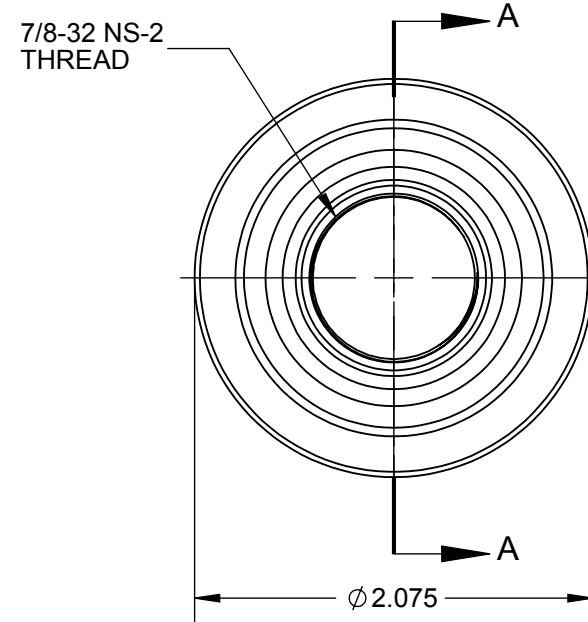

NOTES:

1. MATERIAL: BLACK POLYURETHANE
2. CRITICAL DIM'S ARE CIRCLED AND SUBJECT TO INSPECTION.
3. DIMENSIONS IN PARENTHESES ARE FOR REFERENCE ONLY.
4. ALL DIMENSIONS ARE IN INCHES WITH NOMINAL DIMENSION IN METRIC BELOW.

5. MATERIAL DFARS COMPLIANT.

6. MATERIAL ROHS COMPLIANT.

SEALING DIE	PART NO.	IFU
	D787RP	----

MOLDED PARTS:
GATES, PARTING LINES, AND FLASH PER QUALITY CRITERIA

PROPRIETARY AND CONFIDENTIAL
THE INFORMATION CONTAINED IN THIS DRAWING IS SOLE PROPERTY OF HALKEY-ROBERTS CORPORATION ST. PETERSBURG, FL. ANY REPRODUCTION IN PART OR AS A WHOLE WITHOUT THE WRITTEN PERMISSION OF HALKEY-ROBERTS CORPORATION IS PROHIBITED.

DRAWN BY	JHK	DATE	09-15-75
APPROVED BY		DATE	
MATERIAL			
FINISH			
UNLESS OTHERWISE SPECIFIED:	THIRD ANGLE PROJECTION		
DIMENSIONS ARE IN INCHES TOLERANCES: ANGULAR: ± 1° TWO PLACE DECIMAL ± .01 THREE PLACE DECIMAL ± .005			



Halkey-Roberts

TITLE
FLANGE 780 VALVE

SIZE	DRAWING NO.	REV
A	C787RPFU	B
SCALE	DO NOT SCALE DRAWING	SHEET
1:1		1 OF 1