

DRAWING NO.
C840AMUX

REV
E

Customer Drawing

Revision History			
REV	DESCRIPTION (ECO)	DATE	APPROVED
D	ADD QTY 2 FOR TOP GASKET ECN 4069	6/11/09	L.F.
E	MOVE HOTSTAMP LOCATION AS NOTED ECN 5114	2/16/12	L.F.

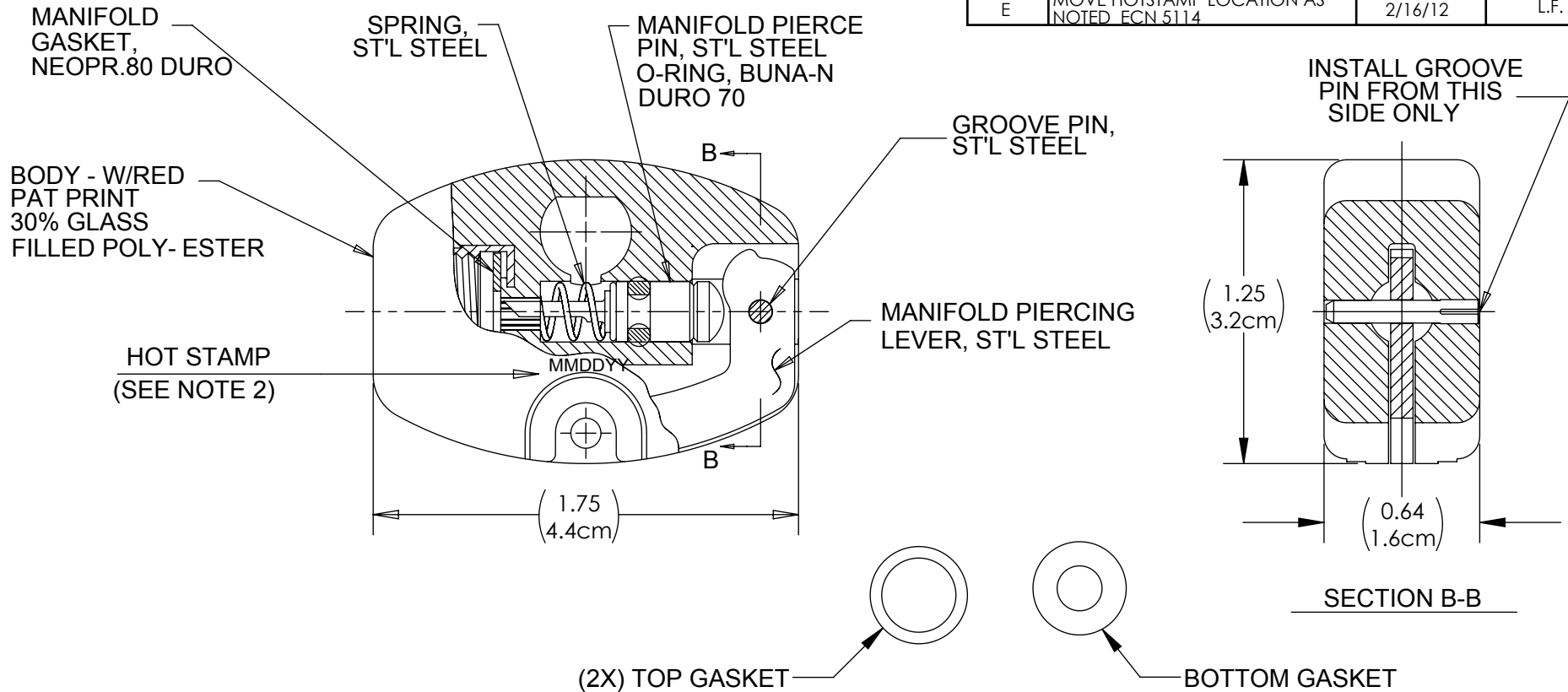

NOTES:

- SUFFIX "X" INDICATES THREAD:
NO SUFFIX - 3/8" TH'D
L - 1/2" TH'D
- MM MONTH
DD DAY
YY YEAR
- TOP & BOTTOM GASKETS PACKED SEPARATELY.
- CRITICAL DIMENSIONS ARE CIRCLED AND SUBJECT TO INSPECTION.
- DIMENSIONS IN PARENTHESES ARE FOR REFERENCE ONLY.
- ALL DIMENSIONS ARE IN INCHES WITH THE NOMINAL DIMENSION IN METRIC BELOW.

MOLDED PARTS:
GATES, PARTING LINES, AND FLASH PER QUALITY CRITERIA

PROPRIETARY AND CONFIDENTIAL

THE INFORMATION CONTAINED IN THIS DRAWING IS THE SOLE PROPERTY OF HALKEY-ROBERTS CORPORATION ST. PETERSBURG, FL. ANY REPRODUCTION IN PART OR AS A WHOLE WITHOUT THE WRITTEN PERMISSION OF HALKEY-ROBERTS CORPORATION IS PROHIBITED.

DRAWN BY	L.F.	DATE	01-15-97
APPROVED BY	J.W.	DATE	01-15-97
MATERIAL			
FINISH			
UNLESS OTHERWISE SPECIFIED:	THIRD ANGLE PROJECTION		
DIMENSIONS ARE IN INCHES			
TOLERANCES:			
ANGULAR: <MOD-PM> 1<MOD-DEG>			
TWO PLACE DECIMAL <MOD-PM> .01			
THREE PLACE DECIMAL <MOD-PM> .005			

	Halkey-Roberts	
	INFLATOR, UL RECOGNIZED (WITHOUT LANYARD & TAB)	
TITLE	DRAWING NO.	REV
	C840AMUX	E
SCALE	DO NOT SCALE DRAWING	SHEET
1:1		1 OF 1