

DRAWING NO.
CV24300X

REV
R

Customer Drawing

REVISION HISTORY

REV	DESCRIPTION (ECO)	DATE	APPROVED
P	Ø.30 WAS Ø0.29 ECO 6488	4/20/15	AK
R	REMOVE SUFFIX GPC, WPC, UPDATE Ø.30 TO Ø.295 ECO 6960	6/10/16	AK

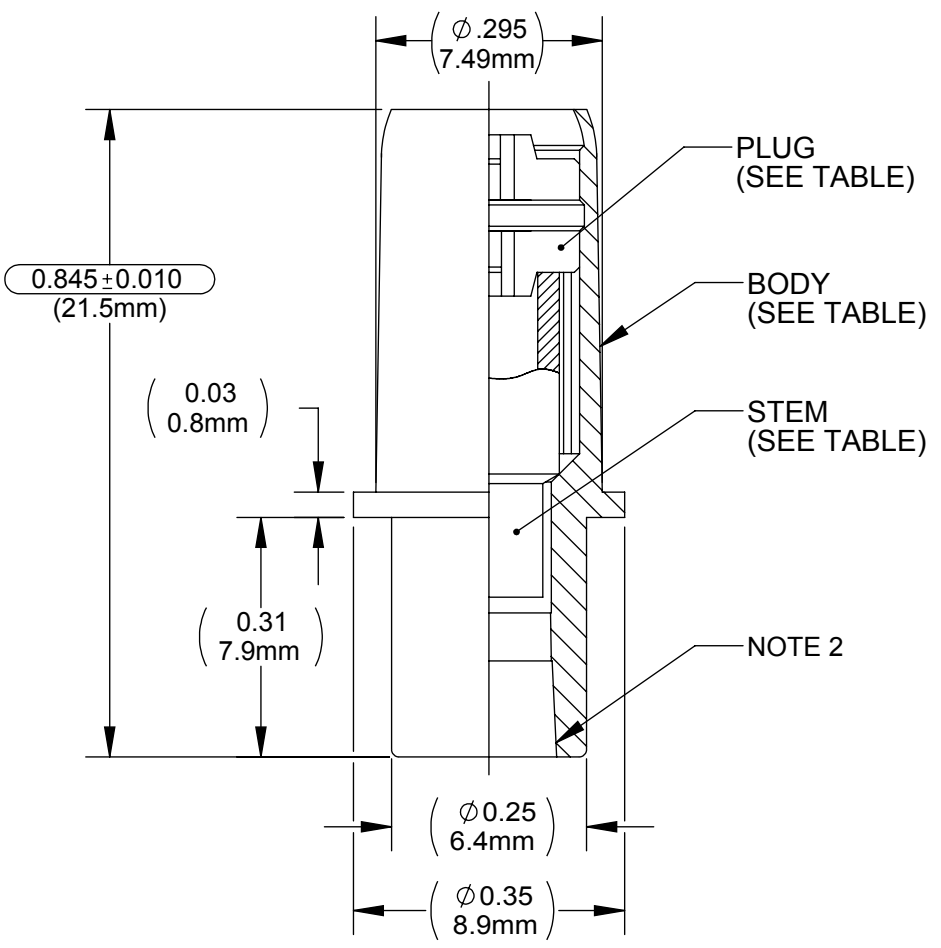

SUFFIX "X"	BODY	STEM	PLUG
P	CLEAR POLYPROPYLENE H0500HN	BLACK SILICONE RUBBER CLS2600HR	POLYPROPYLENE H0500HN
PW	WHITE POLYPROPYLENE PD626 OR P5M6K080	BLACK SILICONE RUBBER CLS2600HR	POLYPROPYLENE H0500HN
V	CLEAR PVC GAMMA 2212RHT1118C040	BLACK SILICONE RUBBER CLS2600HR	POLYPROPYLENE H0500HN

- NOTES:
- CRITICAL DIMENSIONS CIRCLED AND SUBJECT TO INSPECTION. DIMENSIONS IN PARENTHESES FOR REFERENCE ONLY
 - LUER COMPATIBLE WITH ISO594-1

QUALITY CRITERIA:

O.D. FLASH 0.015 MAX. (0.4mm)
GATE VESTIGE 0.01 MAX. (0.3mm)
EMBEDDED PARTICLES, BUBBLES, SPOTS, STAINS: 0.3mm ² MAX. NO MORE THAN 3 PER PART.

MOLDED PARTS:
GATES, PARTING LINES, AND FLASH PER QUALITY CRITERIA

PROPRIETARY AND CONFIDENTIAL
THE INFORMATION CONTAINED IN THIS DRAWING IS SOLE PROPERTY OF HALKEY-ROBERTS CORPORATION ST. PETERSBURG, FL. ANY REPRODUCTION IN PART OR AS A WHOLE WITHOUT THE WRITTEN PERMISSION OF HALKEY-ROBERTS CORPORATION IS PROHIBITED.

DRAWN BY	DMC	DATE	11/18/14												
APPROVED BY		DATE													
MATERIAL	SEE TABLE														
FINISH															
UNLESS OTHERWISE SPECIFIED:	THIRD ANGLE PROJECTION														
DIMENSIONS ARE IN INCHES															
TOLERANCES:															
ANGULAR: ± 1°															
TWO PLACE DECIMAL ± .01	<table border="1"> <tr> <td>SIZE</td> <td>DRAWING NO.</td> <td>REV</td> </tr> <tr> <td>A</td> <td>CV24300X</td> <td>R</td> </tr> <tr> <td>SCALE</td> <td>DO NOT SCALE DRAWING</td> <td>SHEET</td> </tr> <tr> <td>4:1</td> <td></td> <td>1 OF 1</td> </tr> </table>			SIZE	DRAWING NO.	REV	A	CV24300X	R	SCALE	DO NOT SCALE DRAWING	SHEET	4:1		1 OF 1
SIZE	DRAWING NO.	REV													
A	CV24300X	R													
SCALE	DO NOT SCALE DRAWING	SHEET													
4:1		1 OF 1													
THREE PLACE DECIMAL ± .005															

Halkey-Roberts

TITLE: **CATHETER VALVE ASSY.**

SIZE	DRAWING NO.	REV
A	CV24300X	R
SCALE	DO NOT SCALE DRAWING	SHEET
4:1		1 OF 1