

DRAWING NO.
CV24300VG

REV
A



Customer Drawing

Revision History

REV	DESCRIPTION (ECO)	DATE	APPROVED
A		3/18/09	AK

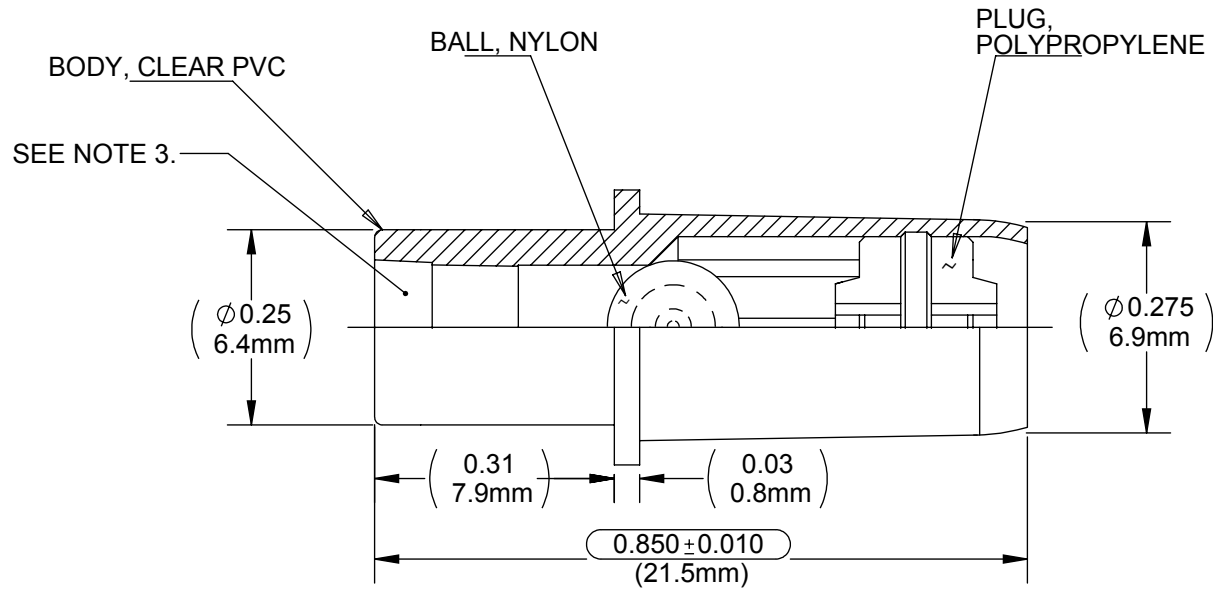

NOTES:

1. CRITICAL DIMENSIONS ARE CIRCLED AND SUBJECT TO INSPECTION.
DIMENSIONS IN PARENTHESES ARE FOR REFERENCE ONLY.

BELOW.

3. LUER COMPATIBLE WITH ISO594-2.

QUALITY CRITERIA:

O.D. FLASH 0.015 MAX. (0.4MM)

GATE VESTIGE 0.01 MAX. (0.3MM)

EMBEDDED PARTICLES, BUBBLES, SPOTS, STAINS: 0.3mm²
MAX. NO MORE THAN 3 PER PART.

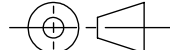
DRAWN BY	M.S.	DATE	11-03-94	 Halkey-Roberts	
APPROVED BY	J.W.	DATE			
MATERIAL	SEE NOTES				
FINISH				TITLE	BALL CHECK VALVE ASSY.
UNLESS OTHERWISE SPECIFIED: DIMENSIONS ARE IN INCHES TOLERANCES: ANGULAR: ± 1° TWO PLACE DECIMAL ± .01 THREE PLACE DECIMAL ± .005				THIRD ANGLE PROJECTION 	SIZE A
MOLDED PARTS: GATES, PARTING LINES, AND FLASH PER QUALITY CRITERIA PROPRIETARY AND CONFIDENTIAL THE INFORMATION CONTAINED IN THIS DRAWING IS THE SOLE PROPERTY OF HALKEY-ROBERTS CORPORATION ST. PETERSBURG, FL. ANY REPRODUCTION IN PART OR AS A WHOLE WITHOUT THE WRITTEN PERMISSION OF HALKEY-ROBERTS CORPORATION IS PROHIBITED.				SCALE 4:1	DRAWING NO. CV24300VG
				DO NOT SCALE DRAWING	REV A
				SHEET 1 OF 2	