

DRAWING NO.  
**C840XBIX**

REV  
**A**

# Customer Drawing

## Revision History

REV	DESCRIPTION (ECO)	DATE	APPROVED
A	NEW DRW. OBSOLETE C840BIXX & C840BILX .ADD TABLE FCN 5271	6/19/12	LF

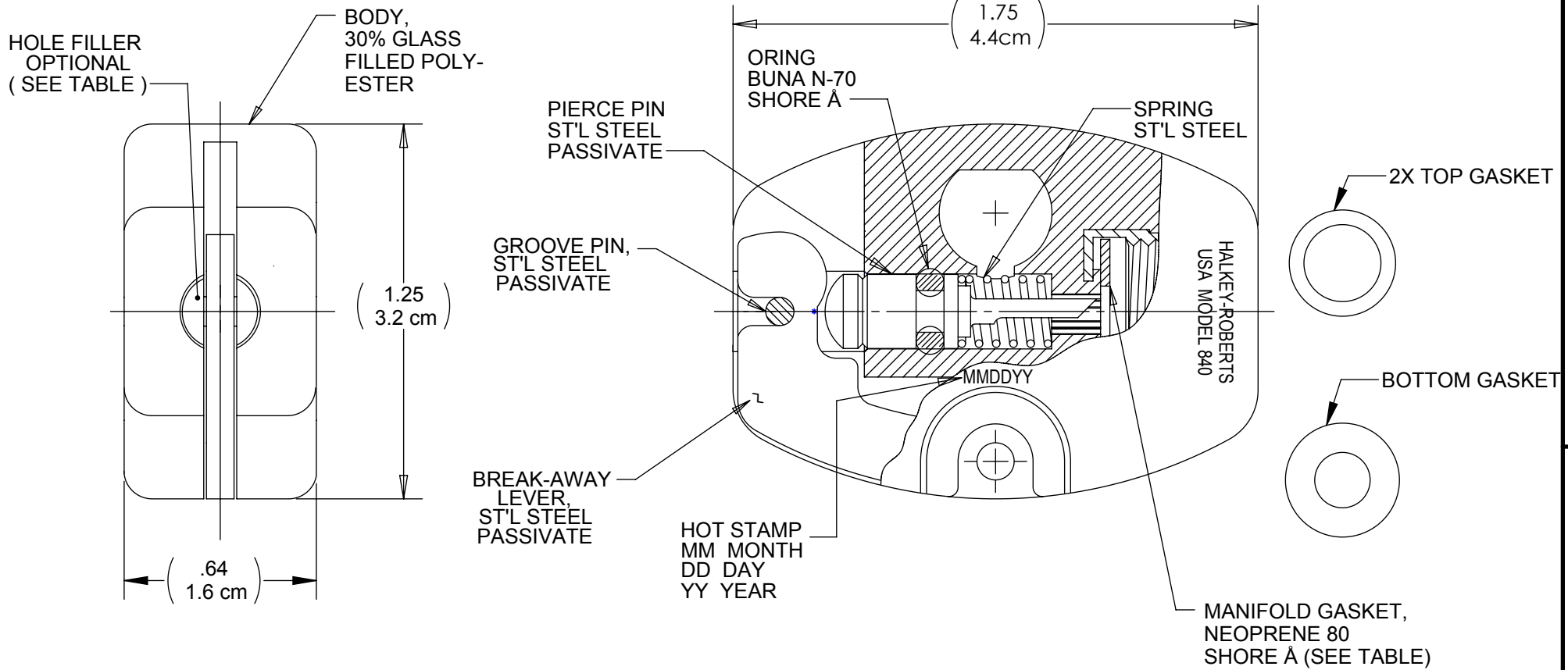

**NOTES:**

- FOR SUFFIX "XX" SEE TABLE
- CRITICAL DIMENSIONS ARE CIRCLED AND SUBJECT TO INSPECTION.
- DIMENSIONS IN PARENTHESES ARE FOR REFERENCE ONLY.
- ALL DIMENSIONS ARE IN INCHES WITH THE NOMINAL DIMENSION IN METRIC BELOW.

P/N	SIZE	GASKET	OPTIONS
8402BI	3/8"	849AM	HOLE FILLER
840BIL	1/2"	849AML	NONE

**MOLDED PARTS:**  
GATES, PARTING LINES, AND FLASH PER QUALITY CRITERIA

**PROPRIETARY AND CONFIDENTIAL**

THE INFORMATION CONTAINED IN THIS DRAWING IS THE SOLE PROPERTY OF HALKEY-ROBERTS CORPORATION ST. PETERSBURG, FL. ANY REPRODUCTION IN PART OR AS A WHOLE WITHOUT THE WRITTEN PERMISSION OF HALKEY-ROBERTS CORPORATION IS PROHIBITED.

<b>DRAWN BY</b>	DMC	<b>DATE</b>	6/19/12
<b>APPROVED BY</b>	LF	<b>DATE</b>	
<b>MATERIAL</b>			
<b>FINISH</b>			
<b>UNLESS OTHERWISE SPECIFIED:</b>	DIMENSIONS ARE IN INCHES		
	TOLERANCES:		
	ANGULAR: <MOD-PM> 1<MOD-DEG>		
	TWO PLACE DECIMAL <MOD-PM> .01		
	THREE PLACE DECIMAL <MOD-PM> .005		
<b>THIRD ANGLE PROJECTION</b>			



<b>TITLE</b>	<b>INFLATOR, BREAK-AWAY</b>		
<b>SIZE</b>	<b>A</b>	<b>DRAWING NO.</b>	<b>C840XBIX</b>
<b>SCALE</b>	1:1	<b>SHEET</b>	1 OF 1